

Boardwalk Hall

YOUR BEST SEAT AT THE SHORE

GENERAL INFORMATION

Boardwalk Hall * 2301 Boardwalk * Atlantic City, New Jersey 08401

Telephone Number (609) 348-7000 Fax (609)348-7206

Website: www.boardwalkhall.com

Management

Spectra by Comcast Spectacor provides Venue Management and Food Services & Hospitality at the iconic Atlantic City Boardwalk Hall.

Spectra's Venue Management division is the industry leader across a full range of services that impact the bottom-line success of public assembly venues, including marketing and sales, corporate partnerships, event booking, ticket services and box office management, customer service, operations and engineering, and finance and administration.

Spectra by Comcast Spectacor is the expert in hosting and entertainment, partnering with over 300 clients at 400 global properties to create memorable experiences for millions of visitors every year. Spectra's expertise is embodied within three divisions: Venue Management (formerly Global Spectrum), Food Services & Hospitality (formerly Ovations Food Services), and Ticketing & Fan Engagement (formerly Paciolan). Learn more at SpectraExperiences.com.

Website: <http://www.spectraexperiences.com/>

Facility Personnel

General Manager..... Fran Rodowicz (609) 348-7061
Asst. GM/Director of Operations. Jim McDonald (609) 348-7017
Administrative Assistant..... Marie Remer (609) 348-7535
Director of Finance..... Josephine Hagmaier (609) 449-2042
Director of Ticketing..... Colin Donohue (609) 348-7801
Director of Corporate Sales..... Kara Cermanski (609) 348-7021
Director of Marketing..... Erin Bilton (609) 348-7072
Marketing Manager..... Elizabeth Marmo (609) 348-7022
Marketing/Group Sales Mgr..... Aura Sanchez (609) 348-7023
Event Manager..... Bill Enkhbayar (609) 348-7016
Operations Manager..... Rick Powell (609) 348-7533
Operations Supervisor..... Darrien Peyton (609) 348-7532

Spectra Food Service & Hospitality

General Manager.....Jose Taroncher (609) 348-2041
Asst. General Manager.....Karl Scheiter (609) 348-2049
Director of CateringSharon Henschel (609) 348-2058



ARENA HISTORY

Historic Boardwalk Hall has played host to a sparkling list of dazzling entertainers and knockout sporting events throughout its 87 year history. A premier entertainment location for visitors and residents alike, this unique seaside arena has helped uphold the city's slogan "Do AC" by bringing exciting events into Atlantic City in addition to their already stellar variety of offerings.

Built in 1929 to host the city's growing convention industry, the historic Hall was touted an architectural marvel at that time. With its large 137 foot-high barrel vault ceiling, the Atlantic City Convention Hall as it was formerly known, laid claim to the world's largest clear span space during that period.



Boardwalk Hall takes pride in a number of firsts. In 1964, it hosted the nation's first major indoor collegiate football game; from July 1942 until November 16, 1945 the Army Air Forces used Convention Hall as a headquarters and training facility during World War II; the country's first indoor helicopter flight was made here in 1970, and Boardwalk Hall was listed on the United State Register of Historic Places as a National Historic Landmark in 1987. In the early years, a number of celebrated artists have performed at Boardwalk Hall including The Beatles, Frank Sinatra, the big band orchestras of Louis Armstrong, Count Basie and Woody Herman, Luciano Pavarotti, The Police, the Rolling Stones and more.



In December 1998, the facility began an extensive three year, \$90 million renovation and restoration that would transform the building into a modern special events arena capable of variable seating for up to 14,770 people. In 2001, the new, more modern Hall was unveiled with much fanfare. Renamed "Boardwalk Hall," the building was officially re-opened with a moving patriotic ceremony held on October 11, 2001 to honor those who serve and protect our country, state and communities.

The innovative renovation received nine architectural and engineering awards, including the 2003 National Preservation Award and Design and Construction magazine's 2002 Renovation Project of the Year.



Since reopening, a host of world-class entertainers and national touring productions have taken the legendary stage, icons such as Lady Gaga, Elton John, Bruce Springsteen, Paul McCartney, Barbara Streisand, Madonna, The Rolling Stones, Jimmy Buffett, Andrea Bocelli, The Eagles, Van Halen, and The Who, among other renowned acts. Boardwalk Hall has also showcased some of the most exciting professional boxing matches carded in recent history, including 2014's Kovalev vs. Hopkins in the WBA and IBF Light Heavyweight Championships, 2013's Adrien Broner vs. Gavin Rees in the WBC Lightweight World Championship, 2012's Bernard Hopkins vs. Chad Dawson in the WBC and Ring Magazine Light Heavyweight Championship, and Ring magazine's 2003 Fight Of The Year, Gatti vs. Ward III. Other popular sports and family entertainment have included the Atlantic 10 Men's Basketball Championship and other NCAA basketball games, the 2012 AHL All-Star Classic, the Atlantic City Boardwalk Rodeo, New Jersey's State High School Wrestling Championships, Walking With Dinosaurs, Disney On Ice, Cirque Du Soleil, Ringling Bros. and Barnum & Bailey Circus, WWE, Philadelphia Soul vs. Las Vegas Outlaws, and "Operation Hat Trick", a charity hockey game comprised of top NHL players which was assembled to raise money for three storm-related charities due to superstorm Sandy.

For ten years since 2003, leading trade publications Billboard magazine and Venues Today have recognized the Hall as either the top grossing mid-sized arena in North America or the World. In 2015, Venues Today recognized Boardwalk Hall as the decade's #1 "Top Stop" in North America and #2 in the World which was based on the venue's box office performance.

ATLANTIC CITY CRDA

The Casino Reinvestment Development Authority (CRDA) oversees Spectra and the management of the Atlantic City Convention Center and Boardwalk Hall. The CRDA's mission is to provide capital investment funds for economic development and community projects that respond to the changing economic and social needs of Atlantic City and the State of New Jersey.



MEET A.C

Meet AC is the sales and marketing force that supports the Atlantic City Convention Center and Boardwalk Hall. Meet A.C provides a full array of marketing services to help ensure successful events in Atlantic City. As the one-stop-shop for planning conferences, conventions, and meetings in Atlantic City, Meet A.C prides themselves on having a knowledgeable staff that is familiar with the local market, media planning and buying, promotions, sponsorships, and creative services.



ATLANTIC CITY SPORTS COMMISSION

The Atlantic City Sports Commission is powered by Meet AC and the CRDA. As Atlantic City continues to grow as a sporting destination, the AC Sports Commission is here to aid that growth and attract additional sports meetings, competitions, and conventions. Recently launched in January 2015, the commission is already off to a fast start in building the new sports identity for Atlantic City.



RECENT NOTABLE EVENTS

A10 Men's Basketball Championships
Albany Devils (AHL)
Atlantic City Boardwalk Rodeo
Atlantic City Comedy Festival
All Stars of Hip Hop
American Idol Live! 2012 Tour
Beyoncé
Bernard Hopkins vs. Kovalev
Carrie Underwood
Fleetwood Mac
Florida Georgia Line
Jason Aldean
Jennifer Lopez and Enrique Iglesias
Kanye West
Kevin Hart
Lady Gaga
Madonna
Marc Anthony
Miranda Lambert
Mother's Day Music Festival
Miss America Pageant
NJ State High School Wrestling Championships
Phish
Ringling Brothers and Barnum & Bailey Circus
R Kelly
The Eagles
The Who
WWE Wrestling
Philadelphia Soul



BOARDWALK HALL PRODUCTION INFORMATION

Meeting Rooms (Main Lobby)

- Meeting Room 111 – 35' x 21'
- Meeting Room 112 – 35' x 21'
- Meeting Room 113 – 23' x 21'

Dressing/Production Offices/Back-of-House Rooms – See Appendix For Layouts

House Stage Right

- Room 104 – 44' x 78' – Catering/Green Room

House Stage Left

- Room 105 – 37' x 40' – Cast Size Dressing Room
- Room 107 – 19' x 13' – Dressing Room w/ Restroom and Shower
- Room 108 – 18' x 23' – Dressing Room w/ Restroom and Shower

Stage Left Corridor (Event Level East)

- Room 114 – 14' x 12' – Green Room
- Room 115 – 16' x 17' – Team Sized w/ Restrooms
- Room 116 – 16' x 17' – Team Sized w/ Restrooms
- Room 117 – 14' x 12' – Green Room
- Room 118 – 14' x 12' – Green Room
- Room 119 – 12' x 17' – Team Sized w/ Restrooms
- Room 122 – 18' x 37' – Coaches Locker Room w/ Restrooms
- Room 123 – 18' x 18' (Lounge), 18' x 9' (Changing Area), 19' x 32' (Dressing Room) – Three-room Suite w/ Restroom and Shower
- Room 130 – 41' x 41' – Catering
- Room 132 – 18' x 18' (Lounge), 18' x 9' (Changing Area), 19' x 32' (Dressing Room) – Three-room Suite w/ Restroom and Shower
- Room 135 – 18' x 20' – Office Suite w/ Changing Area and Restroom/Shower

Stage Right Corridor (Event Level West)

- Room 174 – 19' x 18' – Pyro Room

Event Level (Event Level South)

- Room 150 – 45' x 38' – Media/Catering w/ Private Bathrooms

Automated Teller Machines (ATMs)

- For your convenience, there is an ATM machine in Boardwalk Hall, located on the South end of the concourse level in front of Portal J

Electrical Power

Arena main stage has 3,600 amps of 208/3 phase power and 1,350 amps of 480/3 phase power available for events. Electrical services are located 100' away from the downstage edge of the house stage apron (back wall)

Location	Number	Amperage	Phase	Voltage	Connection
Down Stage Right	2	400	3	208	Wire tails disconnect
Down Stage Right	3	200	3	208	Wire tails disconnect
Down Stage Right	4	100	3	208	Wire tails disconnect
Down Stage Right	4	60	3	208	4 Wire twist lock hub
Rigging Grid	3	450	3	480	Posi-lock connection
Up Stage Right	3	400	3	208	Wire tails disconnect
Up Stage Right	3	200	3	208	Wire tails disconnect
Up Stage Right	2	100	3	208	Wire tails disconnect
Up Stage Right	3	60	3	208	4 Wire twist lock hub
Up Stage Right	4	60	3	208	Wire tails disconnect
Down Stage Left	4	400	3	208	Wire tails disconnect
Down Stage Left	3	200	3	208	Wire tails disconnect
Down Stage Left	2	100	3	208	Wire tails disconnect
Down Stage Left	1	20	1	120	Duplex outlet
Down Stage Left	3	60	3	208	4 Wire twist lock hub
Down Stage Left	4	60	3	208	4 Wire twist lock hub
Up Stage Left	2	450	3	480	Wire tails disconnect

Elevators

Boardwalk Hall has two passenger elevators, three freight elevators, and a stage lift. Freight or other large loads are not permitted on passenger elevators or escalators.

Mississippi Avenue Hallway (East)

- Southeast Freight – 11'8" x 11'8" x 9'4" – 10,000lb capacity
- Southeast Passenger – 4'4" x 5'9" x 7'8"

Georgia Avenue Hallway (West)

- Southwest Freight – 11'8" x 11'8" x 9'4" – 10,000lb capacity
- Southwest Passenger – 4'4" x 5'9" x 7'8"

House Stage

- Downstage left Freight – 10'2" x 18'2" (4'lift) – 2,000lb capacity



Emergency Equipment

Fire systems, smoke sensors, and fire extinguishers are located throughout the arena and office areas. Boardwalk Hall is equipped with two backup emergency generators designed to provide support for power failures.

Features for Guests with Disabilities

The restoration project to Atlantic City Boardwalk Hall's arena was designed to provide enhanced accessibility for our disabled patrons. The arena is compliant with the American Disabilities Act of 1990.

In addition to handicapped parking spaces in the Hall's garage, patrons using wheelchairs will be able to enter and exit the building easily with conveniently located ramps and elevators. Furthermore, our restrooms and concourse areas are easily accessible and special wheelchair seating can be reserved for those who require it for all sporting events, concerts and shows. Call 609-348-7000 for more information about securing handicapped accessible seating.

Floor

The ice floor measures 200' long x 85' wide (standard NHL size) surrounded by 42" high Crystalplex dasher boards. Each board section is removable while still maintaining the 2" ice dam. Atop the dashers on the straightaway is ½" thick plexiglass measuring 42" high. At each end is 5/8" thick plexiglass 72" high. For non-ice events an insulated floor is installed over the ice.

Dimensions

- Total Floor w/ All Retract Pushed In – 292' x 143' (Max Load - 125 lbs/sq. ft.)
- Total Floor w/ Retractable Seating Pulled Out – 263' x 85'

Ice Floor – 200' x 85'

Basketball Court – 112' x 60'

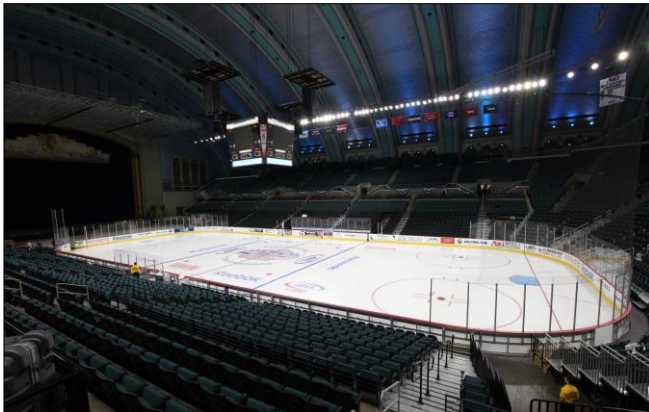

Fire Code Policies - Vehicles

The following requirements pertain to indoor display of fuel operated vehicles:

- Fuel tank must contain a ¼ tank and have a locking cap
- Battery must be disconnected at both leads

- Vehicles may not impede, obstruct or hinder ingress to or egress from the Center and/or the premises.

Forklifts

Boardwalk Hall has five forklifts available for events - four at 6k capacity and one at 8k capacity.

Fork Lift Number	Weight Capacity	Blade Length
1	6K	5'
2	6K	5'
3	6K	42"
4	8K	6'
White	6K	42"

House Curtain

Boardwalk Hall is equipped with black drapery that is available upon request. The soft goods span 143'w x 80'h with additional wing drape of 53'w x 60'h to cover seating sections. Boardwalk Hall owns (8) 10' trusses (20" x 20") that can be used to rig the curtain.

House Lighting

The Arena is equipped with metal halide sport lighting, capable of providing up to 200-foot candle over the floor.

Each fixture is equipped with a motorized shade that completely masks the lighting to allow for immediate black out. In addition, incandescent light accents the arch trusses in the ceiling. The barrel vault ceiling can be illuminated using computer controlled space cannons that can project a full spectrum of colors.

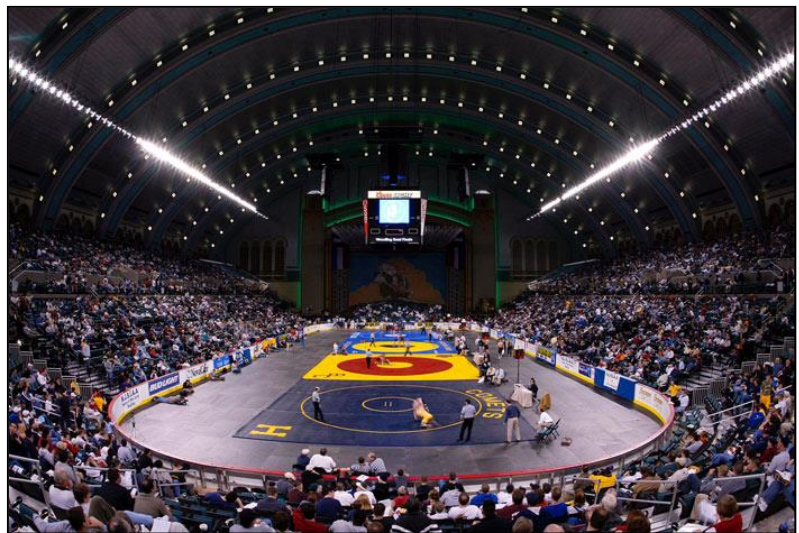

All house lighting is controlled by computer and can be accessed either from the house sound and lighting area in Section 113 or from floor level at Section 102.

Load-in – Upper West Hall

Entrance: Pacific Ave / Georgia Ave

All trucks are unloaded in West Hall (250' from stage front) at the corner of Pacific Ave and Georgia. The 170,000 sq. ft. space is



available for production vehicles, trailers, buses, and other show parking. Boardwalk Hall can unload (6) trucks simultaneously on the load line.

West Hall has 35' ceilings and is equipped with shore power through our floor panels (60amp / 208v in various locations). Max shore power capability is ten (10) buses. The main overhead door for arena access from West Hall is 10'h x 18'w (Georgia Hallway). All show parking must be arranged with the Event Manager. 200amp & 400amp service can be provided as well from the block house in the NE corner of West Hall. Data is derived from the block house as well.

Loading Docks



There are three outdoor loading docks located on Pacific Avenue (100' from Stage Right). The loading dock is not equipped with mechanical dock levelers and there is only (1) dock plate. The 100' push includes a high degree incline into the arena.

Locks and Keys

Dressing rooms may be secured with locks and keys. Keys for each room may be checked out through the Event Manager. All persons who sign out keys will be responsible for return of the keys at the conclusion of the event.

Man Lifts

- (1) 32' Skyjack Scissor Lift
- (1) 28' JLG Scissor Lift
- (1) 125' Boom Lifts

Marquee

There are two (2) 16mm video displays on Pacific Avenue controlled from the scoreboard control room. The physical dimensions of each display are 9'8" high x 12'3" wide. Pixel matrix is 160 x 208 and pixel resolution is 33,280. Pitch is 16 mm. There are two (2) backlit ad panels located below each display. They measure 2' high x



12'3" wide.

Parking

Public parking is available at Boardwalk Hall in the lower East (200 capacity) and lower West (220 capacity) parking garage.

Pyro

Events planning to use pyrotechnics are required to follow strict guidelines established by the State of New Jersey, Department of Community Affairs (DCA), Atlantic City Fire Department (ACFD) and Boardwalk Hall Management. All pyrotechnic displays require a fire detail from the ACFD. The number of firemen necessary will be determined by DCA and ACFD at the time of the demonstration.

Events are required to submit the following information a minimum of 30 days in advance of the show date.

- Stage plot indicating locations of all devices.
- Complete chemical make up of each device.
- Copies of the Pyrotechnician's State & Federal Licenses.
- Evidence of Insurance coverage specific to the pyrotechnic display.

If the Pyrotechnician is not licensed by the State of New Jersey, then a State licensed pyrotechnician must be present and must submit the license information at the time of application.

A demonstration of effects to be used will be required the day of show. After a satisfactory demonstration the DCA Fire Inspector will issue a permit. At any time, the representative from DCA or ACFD may stop the display if in their judgment an unsafe condition exists.

Room 174 is the designated storage room for pyrotechnics. Fire extinguishers are required near the displays. DCA and ACFD will determine the number of extinguishers necessary.

All costs associated with pyrotechnics, including permit fees, Fire Detail, fire extinguishers, magazine storage and State licensed pyrotechnicians shall be bourn by the Event Promoter.

Rigging – See Appendix For Rig Plot

Boardwalk Hall contains a 150'w x 295'd grid which starts 33' upstage of the downstage edge of the House Stage. The grid is 95' to the bottom chord from the ground. All rigging is monitored via load cell readings.

Additional Information

- Max load per panel point is 4,000 pounds. Points can only be rigged to the panel points on the truss.
- Max load applied to each node (hanger point) without engineering approval cannot exceed 12,000



pounds

- Bays are approx. 21', except the center track. Center track is 9'6"
- Truss is aluminum and is made of 26" x 26" truss
- Boardwalk Hall owns 500 GAC slings in-house to wrap the aluminum truss to make the points. No other rigging inventory in-house (i.e. shackles, deck chain, steel for bridles, stinger, motors, etc.). Touring production must provide all equipment from the GAC down to the floor. Boardwalk Hall's GAC must be used to wrap the points so the aluminum is not damaged.
- With engineering approval, high steel (arches) can be used for rigging.
- *Boardwalk Hall has house motors that drop from the arches (high steel) that can be used for rigging. Plot of the house motors can be furnished upon request. All rigging to the house motors must be approved by building engineering*

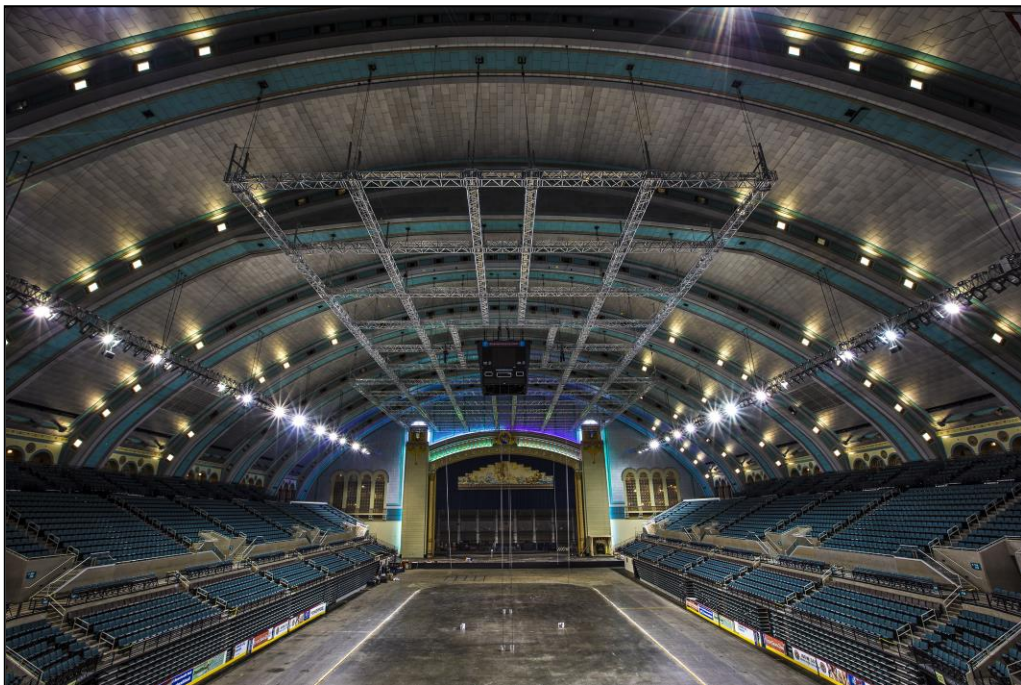

Runners

Boardwalk Hall can provide runners upon request. If you have any special vehicle requirements (e.g. vans, trucks, etc...), please let the Event Manager know in advance. Runners will be paid per day plus any tolls, gas, or other expenses incurred by running.

Scoreboard/Video Production

The center-hung scoreboard system includes four (4) full color 16mm LED video screens. The control room is conveniently located on the arena floor level near the television support room and TV truck parking. The house

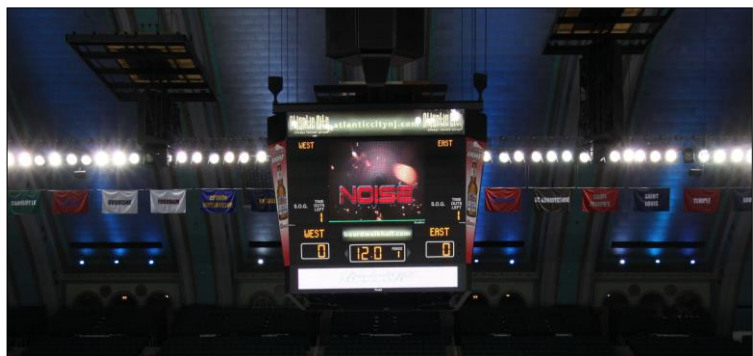

YOUR BEST SEAT AT THE SHORE

equipment includes four (4) Panasonic DV broadcast quality cameras (two on tripods with studio kits, one hand held and one wireless hand held). All have communications back to the control room. The control room is equipped with four (4) svhs decks for replay or playback, DV Pro and Beta SP playback. The control room also has a 20-channel switcher with effects. The system can also take audio/video inputs from outside sources. The system has a video to computer interface and uses Daktronics V-Play system for instant recall stored still and video images. The scoreboard also contains a multi-sport scoring system capable of configuring to a number of different events. The scoreboard trims 92' above the arena floor (3' pokes out underneath the grid)

Screen dimensions as follows:

- Pro-Star size: 7' 6" h x 8' 8" w; pixel count 128 x 160; pitch (pixel density) 16.5 mil.
- Pro-Ad size: 2' 6" h x 15' 8" w; pixel count 24 x 192; pitch 23 mil.

Seating Risers

The south end of Boardwalk Hall can be configured to multiple arrangements to fit your needs. The stage right system is installed with portable clarin seating and the configurations can range from 600 to 700 chairs depending on your requirements.

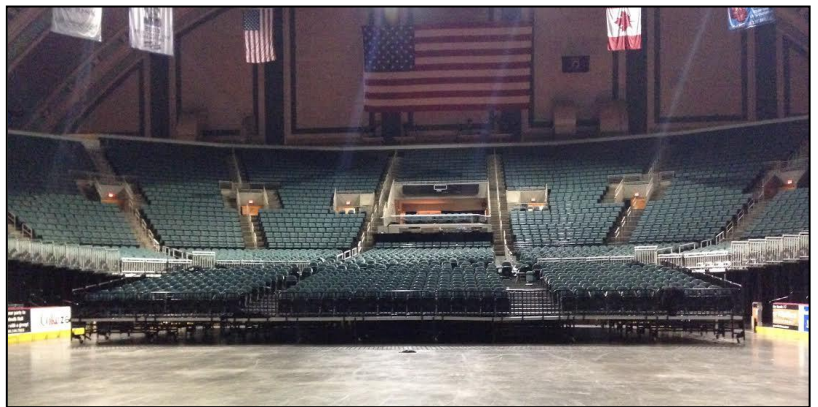

For a full 360 seating arrangement, Boardwalk Hall has the capability to build an additional 672 seats at the north end of the floor by the house stage.

Seating Capacities

Seating capacity for the arena is per management's specifications guide and may vary according to production requirements.

Number of Seats:

End Stage (180 degree House Stage)	14,500
End Stage (270 portable stage)	13,500
End Stage (180 degree portable stage)	12,300
Boxing	13,300
Basketball	12,000
Hockey	10,300

Sound System

The sound system in the arena consists of twenty (20) JBL HLA Series (3 way Horn Loaded Array) center hung speakers, four (4) JBL HLA downfill and a delay ring of twelve (12) custom shop 12 x 1.5" passive speakers. (JBL components) In public areas there are thirty five (35) wall mounted and one hundred seventy two (172) ceiling mounted speakers. (JBL components) There are twenty two (22) Crown Amplifiers, computer controlled by the Crown IQ PIP USP2 DSP system. Signal processing is computer controlled by the BSS SoundWeb DSP System. The Mixer is a Yamaha LS9 digital mixing console 32 channels. There are eight (8) field panels each consisting of twelve (12) audio

lines, two



(2) speaker drive lines, two (2) coax lines, and two (2) channels of production intercom (Telex, ClearCom Compatible) all terminating in a patch field in the main amp room.

Spot Lights

Boardwalk Hall has a total of ten (10) useable spotlights. Four (4) 3000-watt Gladiator 3 spotlights permanently located on the south end of the arena opposite the permanent stage and six (6) 2000-watt Super Trouper 2 spotlights located on the east and west sides of the arena. There is a two-channel intercom system to all spotlight locations. Super troupers are portable and can be placed in the ADA seating sections on the 100 level.

Staging

The arena has a full proscenium stage that measures 48' from proscenium arch to back wall and 40' from arch to the edge of apron (88' in depth). The proscenium opening is 108' wide and 60' high. The stage is 148' wide behind the proscenium and more than 150' wide in front of the proscenium. The house stage is 4' high.

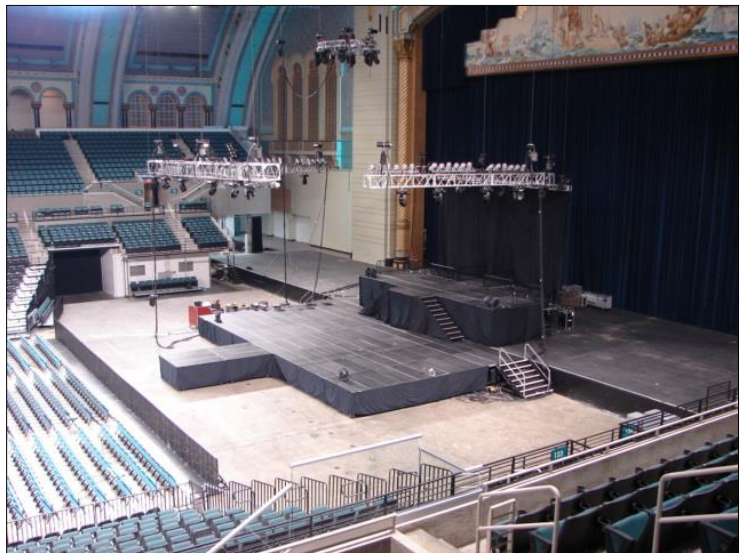

A portable Stageright stage can be added to the apron edge to extend the house stage size or act as a stand-alone stage in front of the proscenium stage. The Stageright equipment can be configured in various ways and production should check with the Event Manager to determine feasibility.

The Stageright stage can be built from 4' to 6' high and maximum dimensions are 80'x 40'. Boardwalk Hall Stageright decks are 4' x 8's. Boardwalk Hall also has various other staging equipment that can be configured into sound wings, camera platforms, mix positions, etc.

Telecomm

Boardwalk Hall is fully wired for voice and data including fiber optics. Each room has voice/ data capabilities with fiber in key locations. Large concentrations of cabling have been installed in various locations including the broadcast location, pressroom, interview room, arena floor center and West Hall to handle temporary press needs. There is free ad-based WiFi throughout the building. Additional non ad-based WiFi and wired connections can be obtained for an additional cost. Telephones can be installed in any of the dressing or locker rooms or other building locations. Public telephones are located on the concourse level, event level and main lobby.

ADRIAN PHILLIPS THEATER INFORMATION AND SPECS



The Adrian Phillips Theater is located on the concourse level of Boardwalk Hall and can stretch upwards to 17,800 square feet of functional event space. The Theater features a distinct house stage with a 48' proscenium opening and an open air loggia which overlooks the famous Atlantic City boardwalk. The Theater is capable of accommodating a variety of events with capacities ranging from 1,000 for catered functions up to 3,000 for concerts and boxing events.

THEATER PRODUCTION INFORMATION

Meeting Rooms

- Room 320 – 41' x 65' (Behind Upper Balcony)
- Room 321 – 42' x 58' (Behind Upper Balcony)

Dressing/Production Offices/Back of House Rooms

Backstage Rooms (Event Level)

- Room 208 – 24' x 13'
- Room 209 – 22' x 27'
- Room 210 – 22' x 39'

Backstage (2nd Level) w/(2) private bathrooms

- Bob H 1 – 13' x 20'
- Bob H 2 – 13' x 8'
- Bob H 3 – 13' x 8'
- Bob H 4 – 13' x 8'



Electrical Power

The house stage is equipped with 800 amps of 208/3 phase power stage right and stage left.

Location	Number	Amp	Phase	Voltage	Connection
Stage Right	1	100	3	208	Wire tails disconnect
Stage Right	1	400	3	208	Wire tails disconnect
Stage Left	1	400	3	208	Wire tails disconnect
Stage Left	1	200	3	208	Wire tails disconnect
Stage Left	1	100	3	208	Wire tails disconnect
Stage Left	8	60	3	208	4 wire twist lock hub

Stage Left	1	20	1	120	Duplex Outlet
------------	---	----	---	-----	---------------

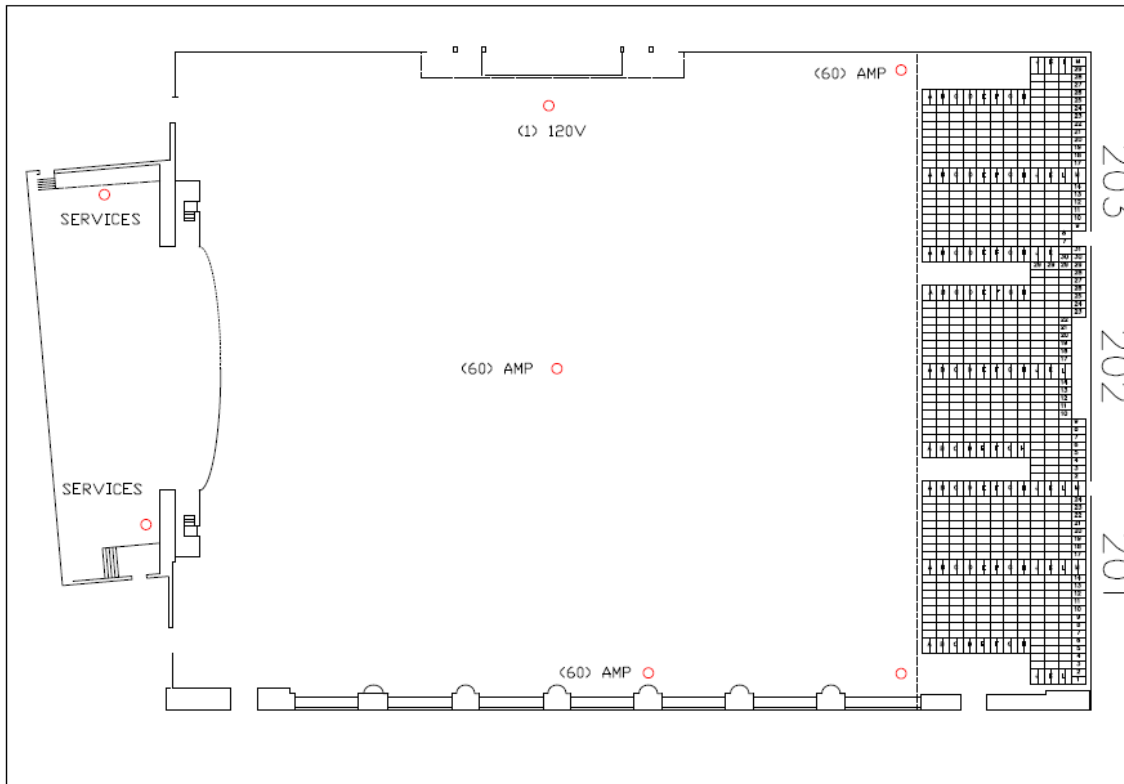

Telecommunications

ISDN line is available through the stage right corridor. Hardline internet is limited to the stage side of the Theater and underneath the permanent balcony (Section 201 – 203). All meeting rooms can be hardwired with internet and the house wireless network is available in all event spaces. Additionally, Boardwalk Hall owns twelve (12) headsets and belt packs for com in the Theater. House com for the room is split into two channels.

Freight Elevators

- Southeast Freight (Miss. Ave.) – 11'8" x 11'8" x 9'4" – 10,000lb capacity
- Southwest Freight (Georgia Ave.)– 11'8" x 11'8" x 9'4" – 10,000lb capacity

Audio Systems

The Theater's audio system was recently upgraded with professional JBL gear for rider friendly operations. The state of the art arrays are complimented by fresh subwoofers, stage monitors, mic kits, and a new front fill system. A Yamaha LS9 console is conveniently located in the organ balcony for control and all speaker and amplifier systems are compatible with Performance Manager Sound system software. The house sound board (Yamaha LS9) can be moved to the center of the floor for a traditional FOH setup.



Below is a listing of the new sound equipment available inside the theater. Detailed listing is located in the appendix.

QTY	Model	Description	Location
20	JBL VTX-V25	Large Format Line Array	SR & SL (Rigged)
6	JBL VT4886	Small Format Line Array	Center Cluster (Rigged)
8	JBL VTX-G28	Dual 18" Subwoofers	Groundstacked
6	JBL AC18/26	Compact 8 inch two-way speaker system	Front Fills
4	JBL VTX-F12	F-Serie Monitor two-way 12" woofer	Monitor Wedges
2	JBL VTX-F18S	F-Serie Single 18" Subwoofer	Stage Monitors

Audio Rig

Stage Right & Stage Left line arrays are rigged 32' off the center line flush w/ the downstage edge of the permanent stage.

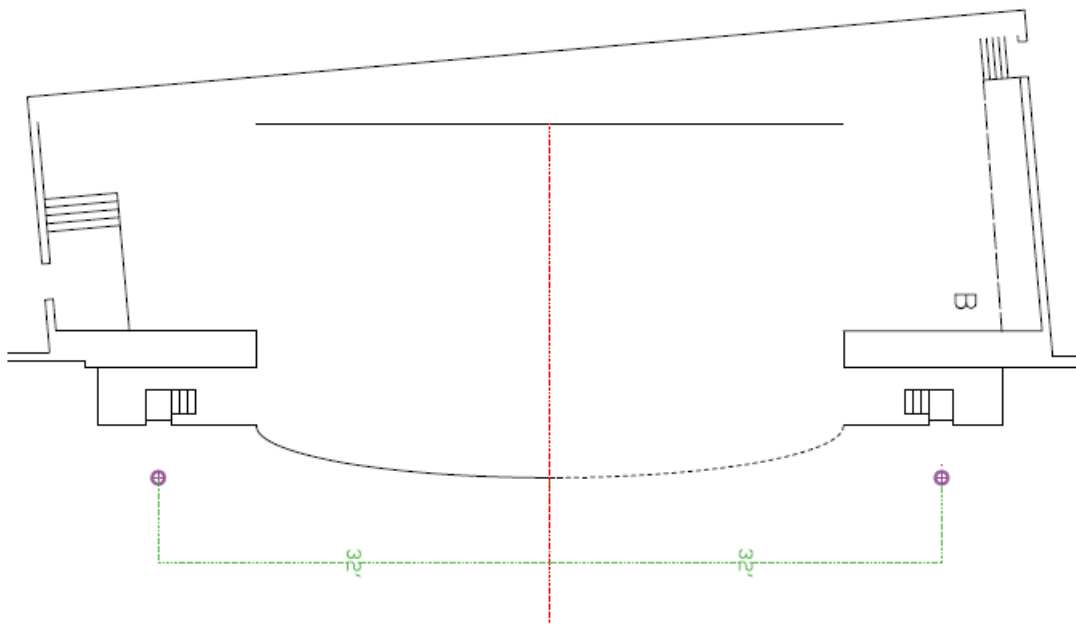

Lighting Systems

Likewise, a new lighting package was installed in the Theater for rider acceptable conditions. The LED fixtures provide concert level lighting and can easily support lighting effects supplied by promoters. All fixtures are LED's and RGBW. The house control console is an AVO Pearl 2008 w/ four (4) DMX universes – a visiting console can output ARTNET or DMX into the console. Similar to the house audio board, the AVO Pearl can be moved to the floor for FOH.

Fixtures:

- (96) – Chauvet Colorado 1 Quad Zoom Tour (Pars)
- (16) – Martin Rush MH1+ Moving Head Profile spots (Movers)
- (16) – Altman Phoenix RGBW LED ellipsoidal spotlights (Lekos)
- (7) – Spectra CYC RGBA (Uplights)
- (4) – Elation Cuepix Panels (Audience Blinders)

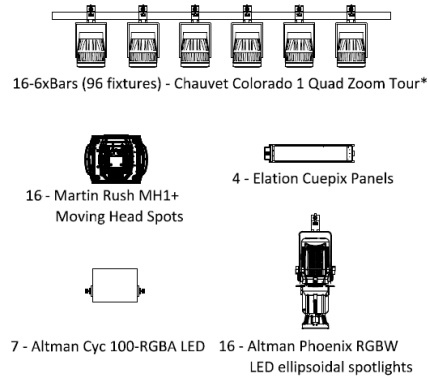

Current Lighting Plot

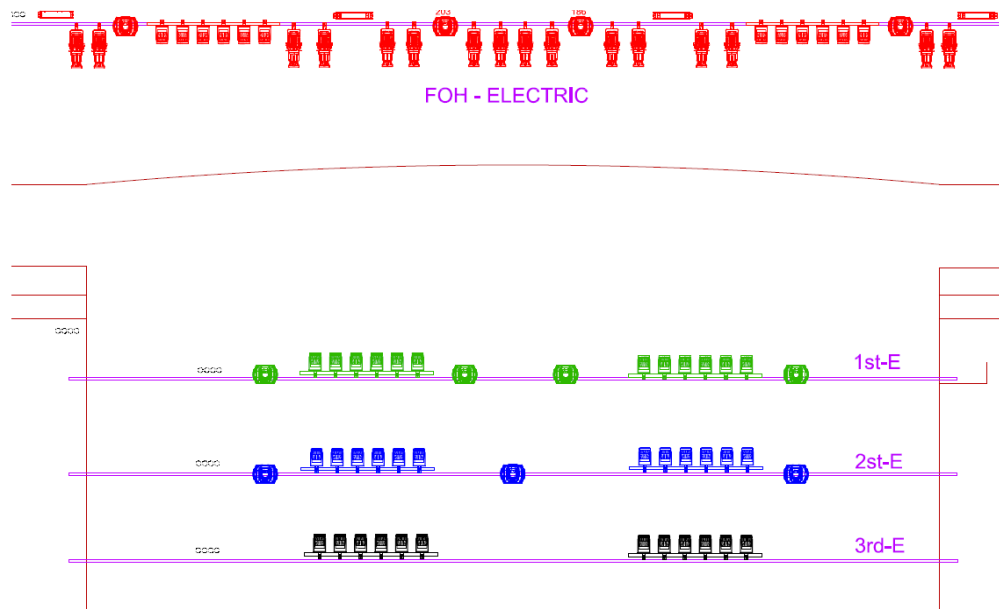

Detailed listing of the lighting equipment is located in the appendix.

Theater Grid

Adrian Phillips houses a traditional theater grid inside the proscenium at a 71' x 15'3" footprint. The steel is 3" in width and runs upstage to downstage w/ 3" spacing in between (6" centers). 5' steel I-beams are rented to distribute load and to allow rigging in anywhere within the grid.

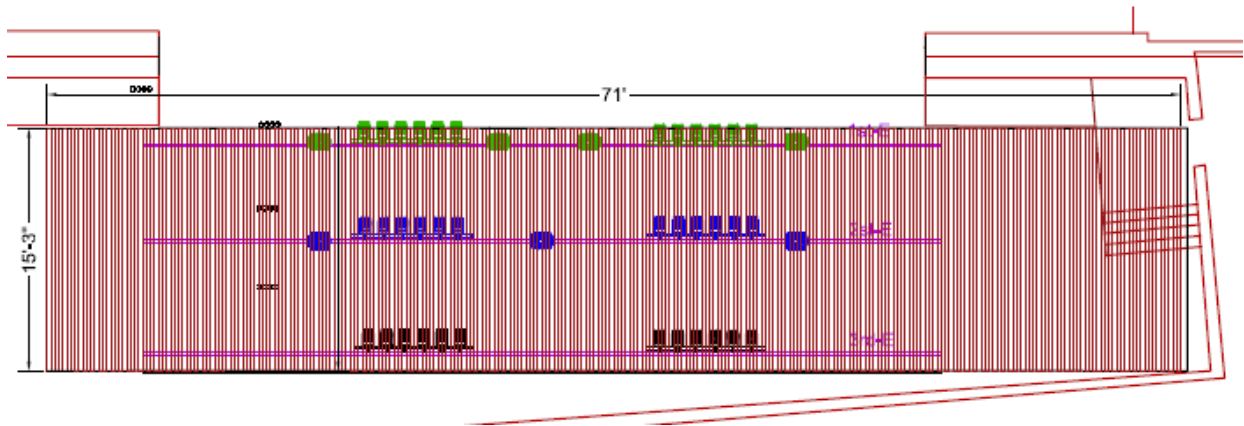

Additionally, line sets can be used for rigging inside the proscenium. Approx. 30 are in working condition.

Video Systems

The Theater possesses a 40'w x 20'h video screen rigged inside the proscenium. Front projection is sourced from the projectors booth above the balcony seating. Throw is 185' from downstage center. The video screen can alternatively function as an upstage cyc as the screen is rigged just in front of the back wall.



Seating Capacity

Seating capacity is contingent upon production requirements.

Below are our basic capacities:

Balcony (Upper Level)	641
Riser (Temporary)	950
Rounds	1,000
Classroom Style	1,326
GA (Open Floor)	2,500
Boxing	2,900
Theater Style	3,200

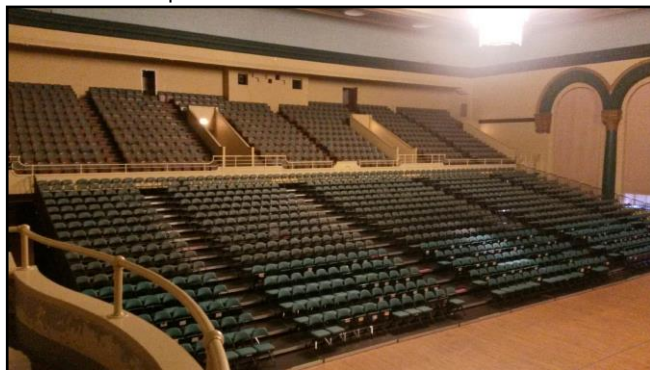

Spotlights

The Theater has two (2) Lyceum Xenon 2000 watt Super Troupers, located in the projection room opposite the stage. Additional spot lights can be built in the seating areas with risers. There are (6) super troupers inside the arena that can be used for the theater.

Theater Dimensions

Proscenium Width – 48'

Proscenium Height – 24'

Stage Depth – 29'

Plaster Line to Upstage Wall – 20'

Plaster Line to DSE – 9'

Stage Height – 40.5"

Roll Door (SR) - 9'10"w x 8'8" h

Theater Grid (From Deck) – 46'h

Front Valance (From Deck) – 18'h

Chandelier (From Floor) – 30'h

Ceiling (From Floor) -55'h

FOH Electric Trim (From Floor) – 32'h



Stage Extension (Downstage)

- Boardwalk Hall is capable of building an additional 40'w x 12'd temporary stage off the permanent house stage. Stage extension is level with the permanent stage.
- Boardwalk Hall owns two stage stairs that lead from the Theater floor to the stage extension.

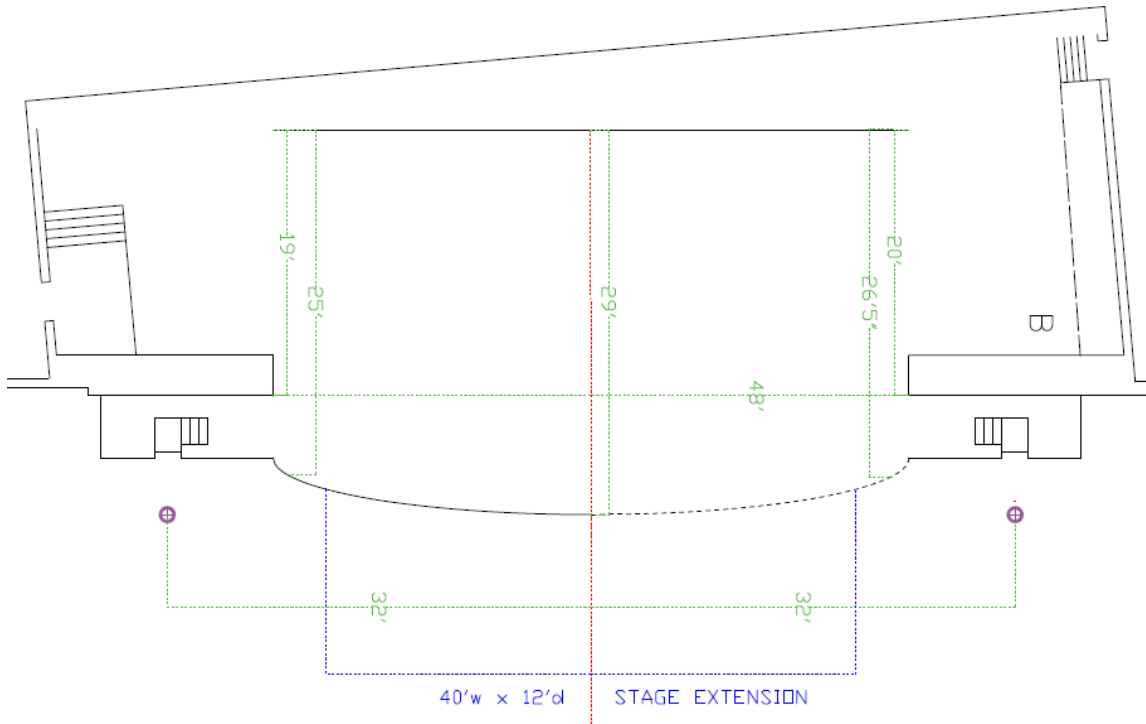

Clear Floor (146' x 122')

- Temporary riser can be removed for an open floor space of 17,800 sq. ft.

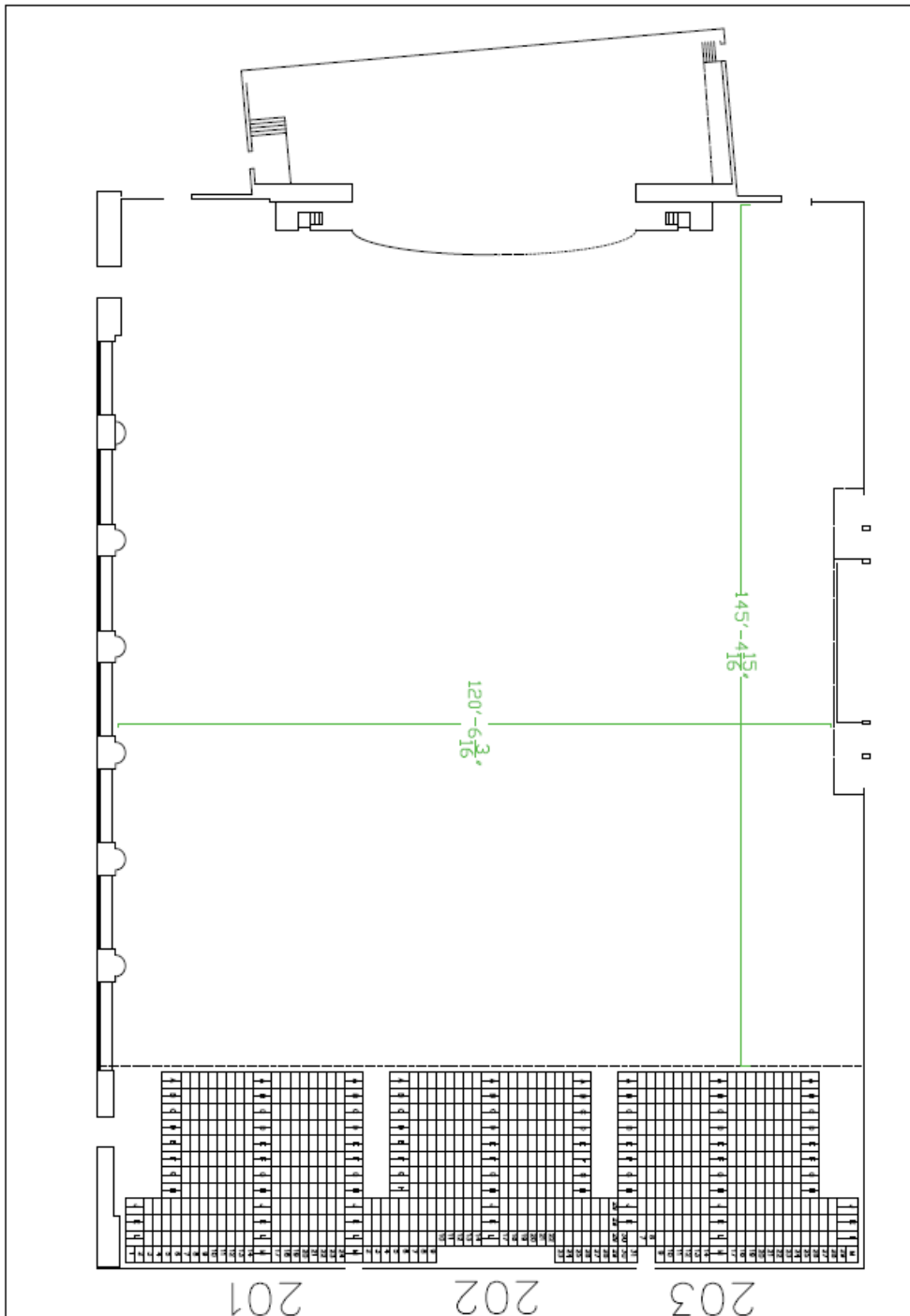

Boxing/MMA Rig

- In-house trussing can be configured into a square box truss (40') or octagon for boxing and MMA events.
- The boxing/octagon rig is hung center house using the existing joists.

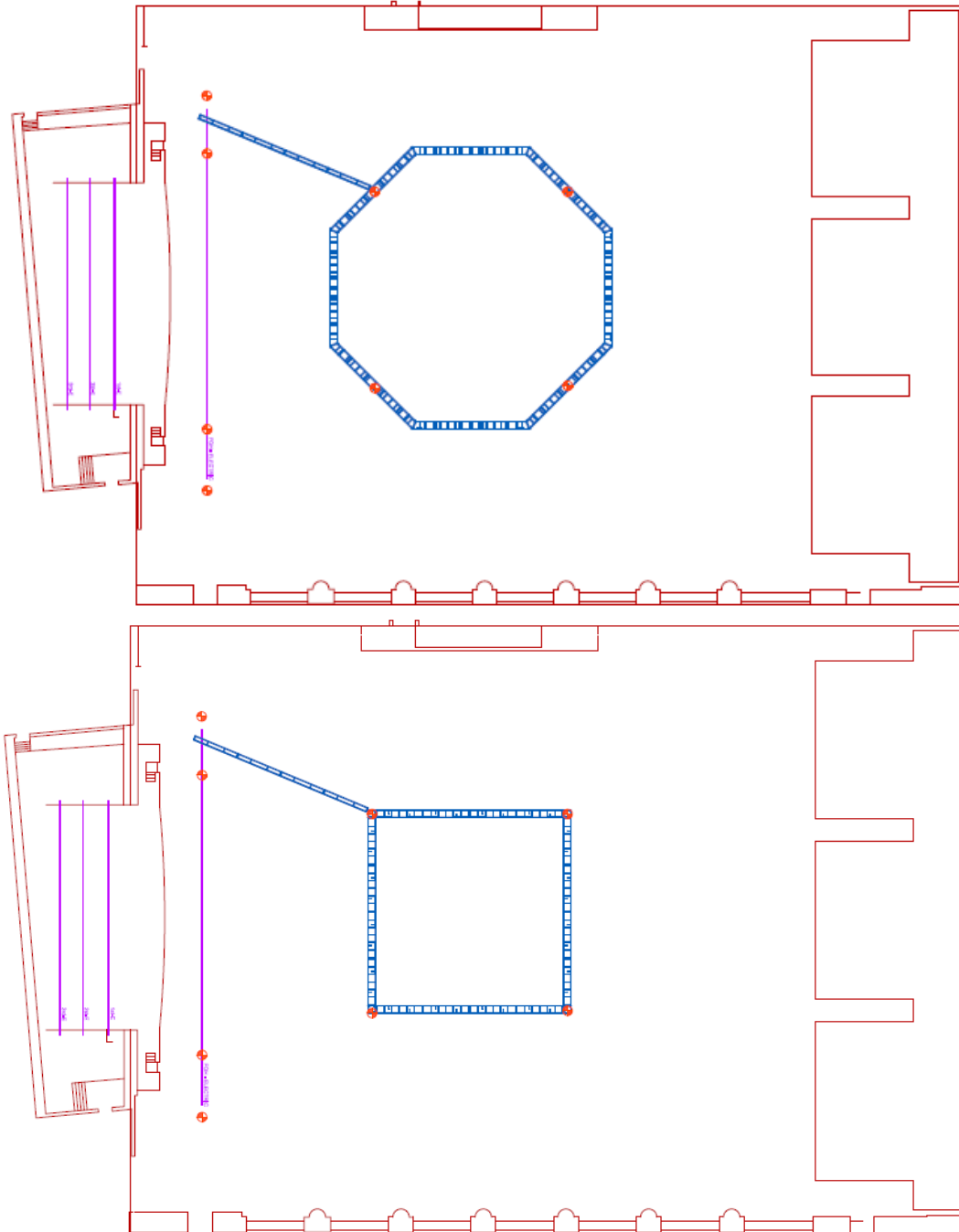

SPECTRA
BY COMCAST SPECTACOR

Boardwalk Hall 23
YOUR BEST SEAT AT THE SHORE

Detailed Audio Listing

Main PA (max load is 268,000 watts):

- 10 JBL Vertec VTX V25 II per side (20 boxes total). Permanently Rigged (SR & SL).
- 6 JBL Vertec VT 4886 . Permanently rigged (center cluster).
- 4 JBL Vertec VTX-G28 Subs per side (8 total). Floor (SR & SL)
- 6 JBL AC18/2 Front Fills (On Deck)
- 10 Crown Itech 4x3400 HD
- 4 Crown Itech 12000 HD
- 1 Crown Itech 9000 HD
- 1 Crown Itech 5000 HD

Monitor System:

- 4 JBL VTX – F12 wedges
- 2 JBL STX 835 Side Fills
- 2 JBL VTX – F18s Subs
- 2 Crown Itech 4x3400 HD
- 1 Crown Itech 9000 HD
- 1 Crown Itech 5000 HD

System FOH Interface Capabilities:

- Yamaha LS9-32 with two Dante Cards
- Yamaha Rio 32 x 16 on stage
- Yamaha Rio 16 x 8 portable
- BSS London Routing system
 - Dante inputs
 - Analog road show inputs (L,R,C,Subs L&R, Frontfill, and Sides) Mix 1-4
- System auto mix for 2 RF microphones, 2 Lavs, and 4 wired microphones
- 6 Analog dry tie lines FOH to stage rack and 6 tie lines stage to booth
- 6 Fiber multi-mode dry lines FOH to stage and booth (ST connectors)
- 6 RG 6 dry tie lines FOH to stage and booth
- 2 each dedicated dry cat 6 And cat 6 shielded tie line FOH to stage and booth
- 4 Cat 6 network to patch bay FOH to stage
- 6 Cat 6 network from patch bay stage and booth
- Dedicated audio system wireless network

Detailed Lighting Listing

Trussing (XSF):

- 4 Corner squares (20" x 20" truss)
- 16 Grid truss at 10' per (20" x 20" truss)
- 8 Octagonal wedges (20" x 20" truss)
- Both rigs (box & octagon) are bridled on four one-ton motor points
- FOH electric is hung on four one-ton joists.
- Cable pick for FOH electric shares grid cable runoff.

Fixtures:

- 7 Cyc lights SScyc100RBGWB (Altman)
- 16 Rush MH1 Profile + (Martin)
- 96 LED Pars Colorado 1 Quad Zoom (6 per lamp bar)
- 16 LED Iekos PHX2-RGBW19B (Altman)
- 16 B size gobo holders for Phoenix Ellipsoidals (Altman)
- 4 Cuepix blinders (Elation)
- House Console – AVO Pearl 2008 (can be placed organ balcony, rear center on the floor, and back stage)

Electric:

- 1 Distro w/ volt & amp meters (Lex)
- All equipment is LED and operates on 120v (can operate on 220v)
- Portable power rack for box/octagon rig is 120v (8) and 208v (4) and 120v duplex (3), L6-20 (3) and L21-30(3)

Cabling:

- 100 powercon/dmx jumpers w/ 1 lot of dmx cable

Misc:

- 1 Enode 8 (Elation)
- 6 Enode 4 (FOH, 1st Electric, 2nd Electric, 3rd Electric, backstage, grid)
- 3 Show baby wireless dmx 1 channel transceivers

Lighting system provides 4 universes via artnet at all locations. All fixtures can be controlled individually with added channels available on each universe.

Standard Theater Set

- Floor – 1,488 cap
- Section 101 – 105 (Bleachers) - 936 cap
- Section 201 – 203 (Upper Balcony) – 641 cap
- Total – 3,065

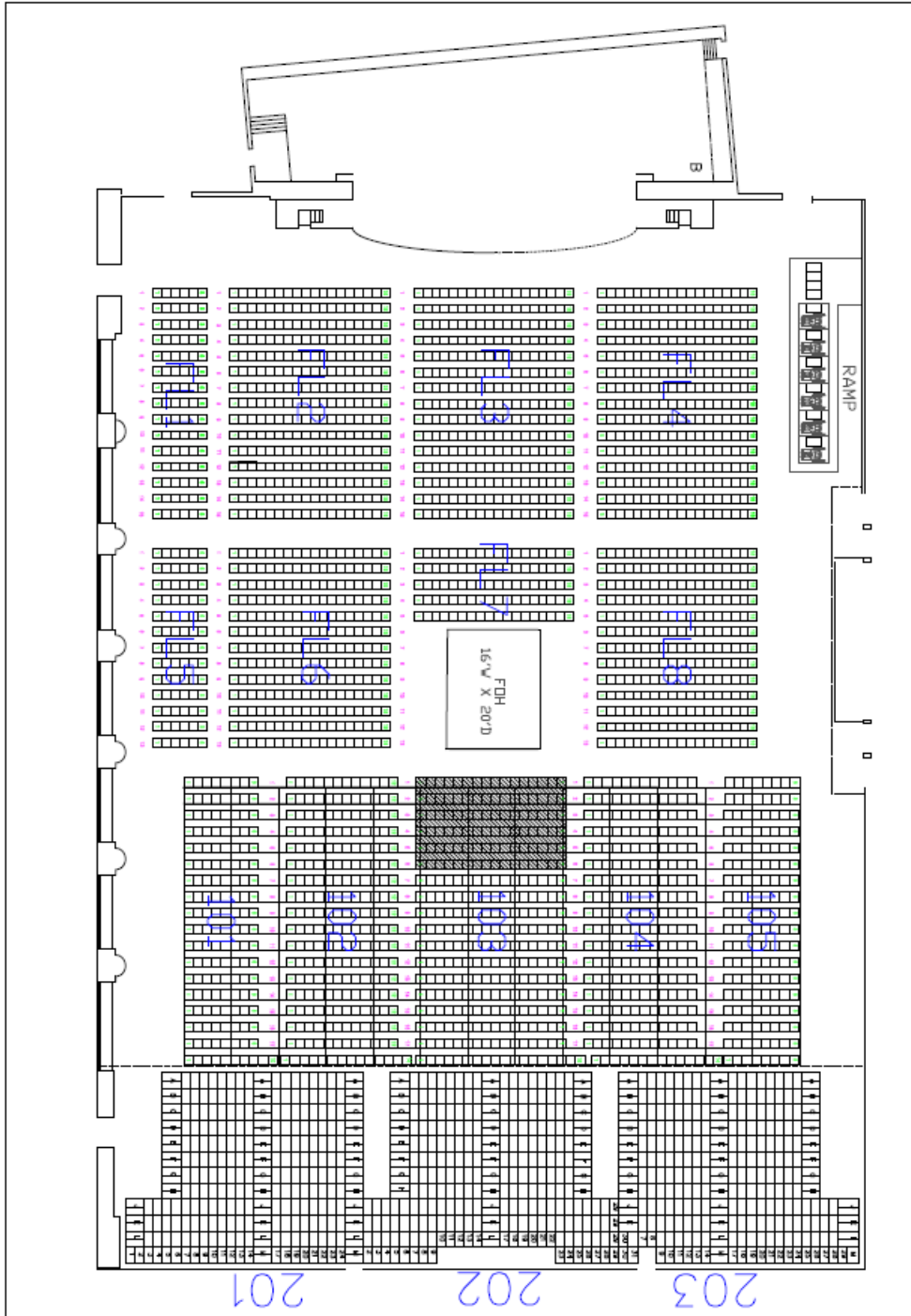

Standard Theater Set With 12' Stage Extension

- Floor – 1,328
- Section 101 – 105 (Bleachers) - 936 cap
- Section 201 – 203 (Upper Balcony) – 641 cap
- Total – 2,905

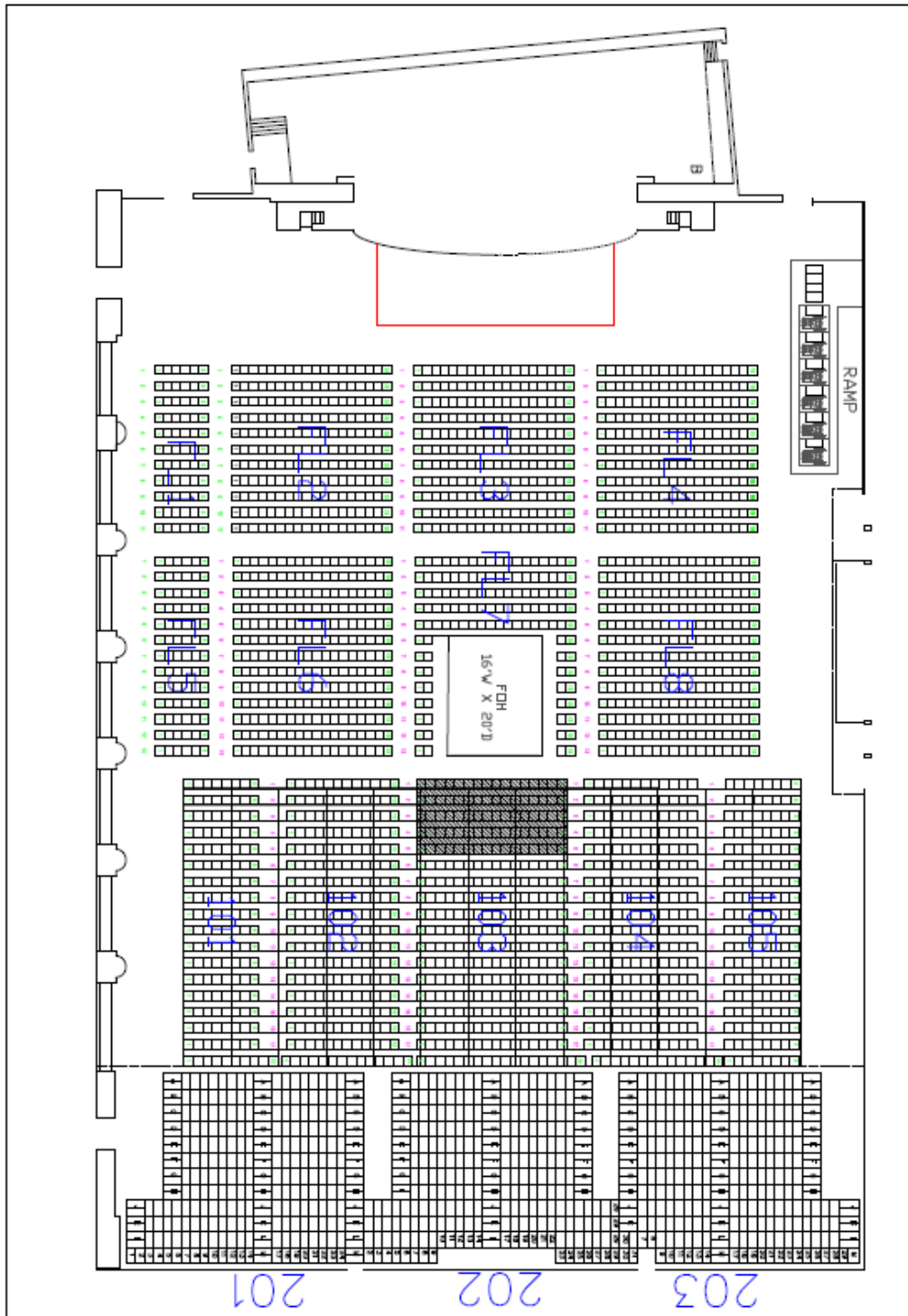

RENTAL RATES/CONDITIONS

Equipment and Service Rates

Boardwalk Hall provides a full-range of event equipment and personnel including ushers, ticket-takers, security, stagehands, cleaning, operations, and technical support.

Rental Rates

Per day facility rental rates are available upon request. All rental rates are negotiable and dependent upon contract terms. Please call (609) 348-7000 for further inquiries.

Taxes: New Jersey state luxury tax is 13% on all revenue

Available Equipment (Rental and rates subject to contract terms):

- Staging
- Chairs
- Barricade
- Basketball Floor
- Bicycle Rack
- Drapery/soft goods (80'w x 60'h)
- Outdoor Marquee
- Risers
- Barriers
- Spotlights
- Forklifts
- Tables (8ft and 6ft)
- Pipe and Drape (limited quantity)
- Furniture
- Sound System and audio headsets
- Portable Audio equipment and microphones
- Telephones
- Shore power

Deposit Requirements and Procedures

A deposit is required as consideration in order to secure a date at the Arena. This amount is due upon execution of the contract or whenever another potential user challenges a date. In case of multiple events, Boardwalk Hall will hold the deposit as a floating deposit unless those dates are challenged, in which case the promoter must provide the additional deposit for each challenged date. Boardwalk Hall Management reserves the right to require an additional sum in advance as a damage deposit, which is refundable after the event is settled and when a check of the facility is completed. Management further reserves the right to require a deposit to cover all estimated expenses, including but not limited to: rent, ticketing fees, staffing, damages, advertising, electrical services and miscellaneous equipment.

Boardwalk Hall has the right to deny use of the facility to any individual, group, organization, or event that does not represent the best interests of the facility. Such decisions will be made at the sole discretion of Boardwalk Hall management.



Ticketing

Box Office

Boardwalk Hall's box office is located in the front of the building and is fully accessible from the Boardwalk with 10 windows. Regular Box Office hours are 11:00am – 5:00pm, Monday – Friday and may vary based upon event activity. The box office accepts cash, traveler's cheques, American Express, MasterCard, Discover and Visa. Personal checks are not accepted.

Ticketmaster is the exclusive ticketing service for Boardwalk Hall. Tickets to all events at Boardwalk Hall can be purchased at the Box Office and all Ticketmaster locations, by calling Ticketmaster charge-by-phone service at 1-800-736-1420, or by logging onto www.ticketmaster.com/boardwalkhall.

Tickets being held for customers at our Will Call Window will be available for pick up beginning four hours prior to a show. Customers are required to present a photo ID and the credit card used to purchase their tickets when picking up tickets.

The Ticketmaster logo is displayed in white text on a black rectangular background. The word "ticketmaster" is in a lowercase, sans-serif font, with a registered trademark symbol (®) to the upper right of the "r".

The use of the Boardwalk Hall Box Office and registered outlets is required, unless noted otherwise in contract, to be used for all ticketed events in order to provide accurate control of receipts and maximum service to patrons.

Boardwalk Hall shall order, audit and determine sales outlets for all tickets sold for events. Boardwalk Hall Management shall have complete custody and control of all monies received from the sale of tickets for the purpose of applying same toward payment of any balance for rent or otherwise due. All money received from ticket sales shall be deemed held in trust by Boardwalk Hall as a bailment for the benefit of ticket purchasers. At no time will tickets be placed on sale unless a contract is signed and record of deposit is on file.

Boardwalk Hall maintains a number of seat licensing opportunities (right to purchase). Please contact our Box Office Manager for further details.

Any consignment of tickets must be approved in advance by the Boardwalk Hall General Manager/ Assistant General Manager.

Settlement

At the conclusion of the event, the licensee is responsible for settling all outstanding facility expenses. Boardwalk Hall will provide a final Box Office statement and settlement of all monies owed upon closing the Box Office for the final performance.

Boardwalk Hall will deduct all applicable State Sales and Luxury Taxes from gross sales of all tickets sold and will remit all taxes due to the State Division of Taxation.

At the close of your event, or on the final day of a multi-day engagement, your Event Manager and our Finance Department



will prepare a final invoice from Boardwalk Hall. This settlement will reflect any advance deposits made and ticket sales held in escrow. Any balance due at the close of the show must be paid prior to departure, unless other arrangements were approved by the General Manager/ Assistant General Manager at least 30 days prior to your event. Your Event Manager will be able to answer any questions regarding final settlement of invoices.

The Spectra Advantage

Spectra by Comcast Spectacor is the expert in hosting and entertainment, partnering with over 300 clients at 400 global properties to create memorable experiences for millions of visitors every year. Spectra's expertise is embodied within three main divisions: Venue Management (formerly Global Spectrum), Food Services & Hospitality (formerly Ovations Food Services), and Ticketing & Fan Engagement (formerly Paciolan).

Venue Management

Spectra Venue Management sets the standard for the industry across a full range of services that impact the bottom-line success of public assembly venues. These include consulting and pre-opening, marketing and sales, corporate partnerships, concert and event booking, ticket services and box office management, customer service, operations and engineering, finance and administration, and management of ancillary services.



Spectra Food Services & Hospitality

This division delivers the industry's most innovative and profitable food services and hospitality management solutions including merchandise management, facility design, marketing and branding, purchasing, consulting and pre-opening, and data and analytics. Specializing in services for sports venues, convention centers and cultural attractions, fairs and entertainment, gaming and hotels, Spectra Food Services & Hospitality serves over 250,000 events and 30 million guests each year throughout North America.

Boardwalk Hall is equipped with a full service kitchen capable of serving a wide variety of menu selections. The concourse has 8 permanent stands and a number of portable locations to service any size crowd. Please contact your Event Manager for menus and contact information.

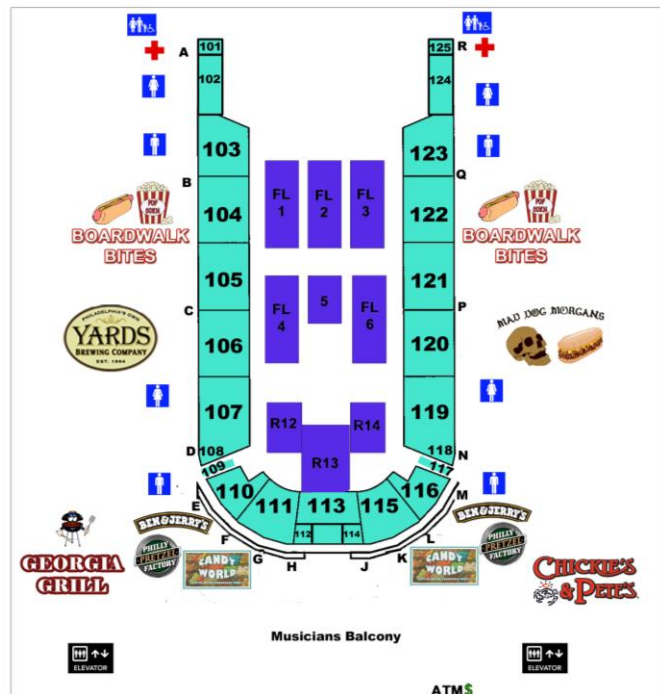

Spectra Ticketing and Fan Engagement

Spectra Ticketing & Fan Engagement is a leader in ticketing and CRM (customer relationship management), fundraising, marketing services, data and analytics, and corporate partnerships. With 35 years of experience delivering superior customer service, revenue growth and life-long fan and patron relationships, Spectra Ticketing and Fan Engagement manages more than 120 million ticket sales per year for live entertainment organizations across the country. Primary markets include college athletics, professional sports and arenas, arts venues and performing arts centers.

For any corporate inquiries, please reach out to Kara Cermanski, Director of Corporate Sponsorships.

Abatis Security

Boardwalk Hall currently employs Abatis for security needs at Boardwalk Hall. Abatis brings a vast knowledge of law enforcement and private security to help clients overcome the daily challenges events bring. They stand behind their company mission: to deliver world class security services, while maintaining a small company feel."



General Admission

General Admission or open floor seating is permitted with arena management approval.

Merchandise/Novelties

All sales of event related merchandising will be controlled by Boardwalk Hall. Boardwalk Hall has two permanent merchandising points, located on the concourse level. Portable locations can be added to adequately accommodate the crowd size.

Marketing and Media Services

As part of our commitment to you, we provide a full complement of services to help ensure a successful event. Whether you're seeking assistance for a concert, a sporting event or a family show, our full-service marketing department is able to assist you with your public relations and marketing needs. Some of the services are available free of charge, others may be fee-based and contingent upon production or size of event. We pride ourselves on having a knowledgeable staff that is familiar with the market, media planning and buying, promotions, sponsorships, public relations and creative services.

Each event booked at Boardwalk Hall can receive significant exposure through Spectra's in-house Advertising Program. See page 31 for a full description of the marketing services we can provide for your event beyond those listed on the next page, for a small additional cost.

Our marketing staff is also available to assist in marketing your event to large groups and organizations in southern New



Jersey through our affiliations with the Atlantic City Alliance and CRDA. Those organizations can provide marketing assistance in their role as the destination management organization for Atlantic City's tourism industry. Contact our Marketing Department at (609) 348-7072 for further information.

Additionally, as a proudly managed Spectra facility, we can use our network of Spectra venues in the Greater Atlantic City Region to help increase the exposure of your event and expand the reach of your marketing message. Other Spectra venues in our market include:

- Wells Fargo Center (Philadelphia, PA)
- Liacouras Center (Philadelphia, PA)
- PPL Park (Philadelphia, PA)
- XFinity Live! (Philadelphia, PA)
- Sun National Bank Center (Trenton, NJ)

If you represent a media outlet seeking further information about the facility, our shows or if you wish to inquire about obtaining credentials to cover our events, we are happy to provide expert assistance.

Media inquiries can be directed to: Erin Bilton, Director of Marketing

The following resources are available for your event*

- Press release and media advisory to approximately 150 local/regional print, broadcast and Internet media outlets.
- Event listing on BoardwalkHall.com and DOAC.com websites.
- Dedicated presale email blast to more than 175,000 addresses.
- Event announcement on ACC&VA's Visitor Information Radio, 1610 AM.
- Placement of event brochures (provided by show promoter) in Boardwalk Hall, Convention Center, and Atlantic City Welcome Centers, located on the Expressway and next to Boardwalk Hall.
- Hot link capability between our building's website and your event website.

Additional Marketing Services are fee-based and may be contingent upon building activity. Please see the appendix for a full description of Spectra's Advertising Program.

Permits

Permits are required for activity in the facility determined to be hazardous. Those activities include, but are not limited to, cooking which produces grease-laden vapors, use of open flame either for cooking, candles or special effects, or use of motorized vehicles. The New Jersey Department of Community Affairs - Division of Fire Safety must approve any of these activities. Your Event Manager will assist you in procuring the necessary permits for your event.



IATSE 77

- **Jurisdiction** – Production elements (e.g. audio, lighting, video, etc.) pertaining to the move-in, performance, and move-out of events.
 - Includes:
 - Unloading/Loading Trucks
 - Spotlights & Lasers
 - Wardrobe
 - Stage & Scenic Carpentry
 - Props
 - TV Support
 - Camera Operation
 - Rigging
 - Utility Work (Cable Pull, Cable Paging, Cable Wrap)
 - Special Effects (Confetti & Pyro)
- **Regular Time** – First (8) hours of the work day.
- **OT (Time & One-Half)** – Over (8) hours in a day and hours between 12:00am – 6:00am. Hours over 40 in a week (Monday – Sunday) is considered OT.
- **Workweek** – Begins Monday and ends the following Sunday.
- **Commercial Rate/TV Rate** – Applies if there is over 30 minutes of recording or if 3 minutes of actual footage is used for any show (i.e. filming or recording commercials, TV or internet broadcasts and motion pictures). Clock begins the moment footage starts recording and cumulates for the entire working call, there are no time resets.
 - Commercial rates depends on location: e.g. if the arena is being filmed the entire working crew in the arena will receive commercial rate. If it is in a separate room that is non-arena (e.g. dressing room) solely the crew inside the room will receive commercial rate.
 - The sole exemptions are archival films and sporting events.
- **Hazard pay** – Stagehands receive hazard rate when work is done over 12' above the floor on temporary fixtures (e.g. truss spot)
- **Meal Break** – Must be given not before the 4th and not after the 6th hour.
 - Can be provided a 30 minute break, but will be paid the entire hour.
 - House can go dark and hands will not be paid that hour.
 - Call back after meal break is (2) hours minimum.
 - Meal penalty is OT for hours worked until break is given.
 - Need subsequent breaks



between 3rd and 5th hour following conclusion of the 1st break.

- **Rest Time** – Stagehands require an (8) hour turnaround time or they will remain at the OT rate.
- **Holiday** – OT for the first (8) hours worked and doubletime after the first (8) hours.
- **Department Heads** – Need a minimum of (4) Heads on all calls (minimum head requirements are on a call by call basis).
 - All Heads are working.
 - Steward can be an acting Head unless the Steward is above the call (Steward is above after 8 hands).
- **Show Call** – Will need a minimum of (4) Heads and (1) Steward (if the Steward is above the call)
 - House Lights are operated by IATSE.
 - If the in-house space cannons are in use for the Show will need IATSE to operate lighting board.
 - Spots, wardrobe, cable pagers, house lights, fork ops, etc. are in addition to the (4) Head minimum.
- **Rigging:** 2 up / 1 down per dead hang. 4 up / 1 down per bridle. Riggers pull from the grid.
- **Arena Minimums:**
 - (6) Hour minimum for all hands during the load-in.
 - Riggers receive (8) hour mins on the load-in.
 - Show call is a flat fee for (4) hours. If show call exceeds (4) hours all stagehands are on OT (30 minute increments) until the show is completed.
 - Work done after show call is in OT unless it is a load-out - hands working the load-out from show call are hour for hour not on 30 minute increments.
 - (4) Hour minimum for all hands on the load-out.
 - Riggers receive (6) hour mins on the load-out.
- **Adrian Phillips Theater Addendums (Stand Alone Events Only):**
 - (4) Hour minimum for all hands during the load-in and load-out.
 - Riggers receive (6) hour mins on the load-in and (4) hour mins on the load-out.
 - Staffing minimum of one head per department as needed – no less than (2) heads to maintain a show.

IBEW 351



- **Jurisdiction** – Show power & electrics, cable utilities, data & telecomm, and lighting work for production.
- **Minimum Call/Coverage** – (1) Foreman and (2) Journeyman on all labor calls – calls change depending on the amount of work needed (e.g. # and distance of feeder run, genie power, shore power, # of service connections, etc.) and the type of work.
 - Will need at least (1) Foreman to run electric to motors during pre-rigs
- **Regular Time** – First (8) hours and hours worked between 6:00am and 6:00pm (Monday – Friday) for the **first (5) IBEW** on the call.
 - Supplemental Journeymen (**after the first five IBEW on the call**) are on straight time for the first (8) hours worked in a day between the hours of 6:00am – 12:00am (Monday – Sunday).
- **OT (Time & One-Half)** – Over (8) hours and work done after 6:00pm for the **first (5) IBEW**.
 - All hours worked after 6:00pm on Friday as well as all hours worked on Saturday/Sunday is OT for the **first (5) IBEW**.
 - Supplemental Journeymen (**after the first five IBEW**) receive OT after 8 hours worked in a day or past 40 hours in a week. Supplemental Journeymen are also on OT from the hours of 12:00am – 6:00am any given day.
- **Workweek** – Begins Monday and ends the following Sunday.
- **Meal Break** – Same as IATSE.
- **Holiday** – Doubletime for all hours worked.
- **Minimums** – All are on (4) hour minimums.
- **Adrian Phillips Theater Addendum (Stand Alone Events Only):**
 - First (8) hours worked any day (Monday – Sunday) between 6:00am and midnight is regular time for all IBEW electricians.
- **Splits:**
 - Loaders – 3:1 split of IATSE & IB (e.g. 16 Loaders splits into 12 IATSE & 4 IB).
 - Lighting/Electrics – 1:1 split w/ IATSE (e.g. 12 Lighting hands on call splits into 6 IATSE & 6 IB).
 - Cable page & Utility work (sporting & televised events) – 1:1 split w/ IATSE.



BOARDWALK HALL RULES AND REGULATIONS

Alcohol

No alcoholic beverages may be brought into Boardwalk Hall. Alcoholic beverages will be sold by Food and Beverage services during events.

Cameras/Recording

The use of video or audio recording devices is strictly prohibited at Boardwalk Hall. Still cameras may be used for some shows or events. The use of such devices will be determined on a show-by-show basis by the show, promoter and the facility management. Members of the media on assignment should contact the Marketing Department at 609-348-7072 for photographer's credentials.

Children's Entry

Generally, children under the age of two will be permitted without a ticket into Boardwalk Hall provided that the child does not occupy a seat (subject to change per show management). Some family shows may have a separate policy. Please contact your event manager for show policies on tickets for children. Children must be accompanied by a parent or guardian at all times while in the building.

First Aid Services

Emergency Medical Personnel (EMS) is present at all times for the safety of our guests and participants. Persons requiring non-emergency first aid assistance can either visit our Security Command Post located on the concourse behind portal H or Guest Services, located on the concourse behind portal K. In an emergency situation, guests should contact Boardwalk Hall security or ushers who will contact EMS.

Guest Services

Guest Services is located on the concourse level of the building behind portal K. At Guest Services, you will find Lost and Found, Group Sales and special needs information and more. You can also purchase tickets or acquire promotional information.

Guest Attire

In order to uphold our status as a first-class entertainment facility, proper attire, including shirt and shoes is required of all guests attending events at Atlantic City Boardwalk Hall or entering the facility to purchase or pick up tickets. Management reserves the right to refuse admittance to anyone it deems dressed inappropriately.

Guest Conduct

Boardwalk Hall strives to provide its guests with a safe, comfortable, and enjoyable atmosphere. Therefore, the Arena has established the following guidelines:

1. Guests interfering with other guests' ability to enjoy the event may be subject to ejection
2. Guests using foul or abusive language or inappropriate or unacceptable gestures may be ejected from the

Arena



3. Guests appearing impaired may be ejected from the premise.

Leaflets/Brochures

Distribution of any printed materials, or selling of any items is prohibited on the Arena grounds, including the parking lots, walkways and inside the Arena unless permission from Boardwalk Hall have been granted.

Lost and Found

Items lost by a guest in Atlantic City's Boardwalk Hall may be claimed at Guest Services on the concourse. Guests are reminded that they are responsible for their own belongings at all times. Turning found items in to Guest Services is appreciated by the management and by your fellow guests. To claim items during business hours, please call 609-348-7000.

Re-entry

Re-entry for ticketed guests is not permitted. Boardwalk Hall is a smoke free facility. Contact your event manager regarding smoking areas or special accommodations your event may need.

Search

Anyone entering Boardwalk Hall may be subject to a physical search and/or metal detection.

Re-selling of Tickets

Re-selling of tickets by private parties is prohibited on the property.

Selling of Illegal Merchandise

Selling of illegal merchandise is prohibited on property as by law.

Security Operations

Boardwalk Hall has contracted with an exclusive security provider for all event-related security, ushering and ticket taking. Boardwalk Hall management and its security contractor will coordinate security needs with your event, but will maintain control of security operations at all times. Boardwalk Hall security, ushers and ticket takers are uniformed at all time and are equipped with flashlights. If advanced security is required (bomb sweeps, armed escorts, etc.) your Event Manager can coordinate requests with either our security contractor or the Atlantic City Police Department.

Smoking

For the comfort and convenience of our guests, Atlantic City Boardwalk Hall is a non-smoking facility. This policy will be strictly enforced in all areas of the building.



Prohibited Items

The following items are not permitted in Boardwalk Hall:

- Aerosol Cans
- Air horns
- Alcoholic beverages or illegal drugs
- Animals (except certified service dogs for the disabled)
- Beach balls and other inflatables
- Bota bags or wine skins
- Bullhorns or noisemakers
- Cameras (varies on events)
- Confetti
- Fireworks, Firearms, or other weapons
- Framed backpacks
- Glass bottles or aluminum bottles
- Ice chests or thermo containers
- Laser pointers
- Outside food or beverage
- Selfie Sticks

Local Information

Hotels/Casinos

Bally's

Park Place & The Boardwalk
Phone: 609-340-2000
Website: www.ballysac.com



Borgata Hotel Casino & Spa

One Borgata Way
Phone: 609-317-1000
Website: www.theborgata.com



Caesars

2100 Pacific Avenue
Phone: 609-348-4411
Website: www.harrahs.com



Golden Nugget

Huron Avenue & Brigantine Boulevard
Phone: 800-777-8477
Website: www.goldennugget.com/atlanticcity



Harrah's

777 Harrah's Boulevard
Phone: 609-441-5000
Website: www.harrahsresort.com



Resorts Casino Hotel

1133 Boardwalk
Phone: 609-344-6000
Website: www.resortsac.com



Tropicana Casino and Resort

Brighton Avenue & Boardwalk
Phone: 609-340-4000
Website: www.tropicana.net



For complete Atlantic City information, visit www.atlanticcitynj.com.



Directions

Atlantic City Boardwalk Hall is located at 2301 Boardwalk at the center of the world-famous Boardwalk. The venue is bounded by Pacific, Georgia and Mississippi Avenues. West Hall is bound by Florida, Pacific and Georgia Avenues.

From North Major Interstate Highways

Connect with the Garden State Parkway south. Take exit 38 to the Atlantic City Expressway.

From I-95

From the south, I-95 to Delaware Memorial Bridge to Route 40 to Route 322, or via Lewes, Delaware, take the Cape May-Lewes Ferry to Garden State Parkway North, to Atlantic City Expressway.

The Atlantic City Expressway takes you right into Atlantic City. Follow signs for Pacific Avenue on the foot of the Expressway.

Make a right onto Pacific Avenue; Boardwalk Hall is located on the left next to the former Trump Plaza Hotel and Casino. Make a left on Georgia Ave. for loading dock access.

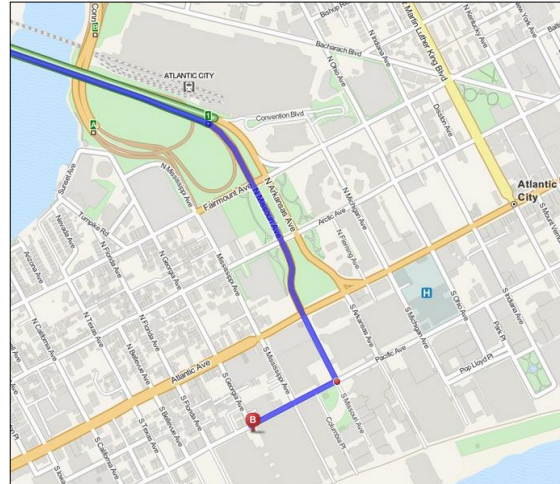

Public Transportation

The NJ Transit Rail Terminal is directly adjacent to the Atlantic City Convention Center and connects Atlantic City to Philadelphia at 30th Street Station and Amtrak's Northeast corridor lines. Historic Boardwalk Hall is located less than 1 mile from the Rail Terminal. For more information, call 973-275-5555, or visit their website at www.njtransit.com.

The Atlantic City Jitney Association and New Jersey Transit have joined together to provide a free shuttle service between the Atlantic City Rail Terminal and all the casino locations in Atlantic City. When you arrive at the rail terminal, use the Kirkman Boulevard exit. In front of the convention center on Kirkman Boulevard there are four Jitney stops with signage identifying each of the casinos. Jitneys depart the train station shortly after each train arrives.

Jitneys also provide free service for your return trip to the Atlantic City Rail Terminal. Jitneys pick up passengers at designated stops at each casino exactly 30 minutes before the departure of each train. The designated stops are marked "Train Shuttle" and are located at or across the street from where you were dropped off when you arrived.

*Estimated travel time between locations is approximately 8 to 15 minutes, depending on your final destinations.



Atlantic City International Airport (ACIA) is an easy 20-minute drive from Atlantic City. Scheduled carriers servicing ACIA include Spirit Airlines and United. Philadelphia International Airport is about 60 minutes away. For more information about Atlantic City International Airport, visit www.sjta.com/acairport

PLEASE NOTE: *This Production Guide is intended to provide basic information to prospective promoters and business partners. To confirm production and operational questions, please contact your Event Manager.*



MARKETING ADVERTISING PROGRAM

Advertising Program

The Advertising Program is a service we offer, as a local marketing agency, to promoters booking events at Boardwalk Hall, the Adrian Phillips Theater, and the Atlantic City Convention Center, allowing them to utilize a number of assets and services that we have at our disposal. Please contact a member of the marketing department to discuss your event needs and what options will best sell tickets.



APPENDIX

Seating Section Capacities - Standard Sport Set

Lower Level				2nd Level		3rd Level	
SECTION	RETRACTABLE	PERMANENT	ADA	SECTION	# OF SEATS	SECTION	# OF SEATS
101		25	2	201	112	303	63
102		105	15	202	180	304	74
103	149	95	15	203	274	305	91
104	180	95	15	204	177	306	74
105	180	95	15	205	275	307	91
106	180	95	15	206	177	308	63
107	180	95	15	207	274	318	63
108		58	6	208	231	319	91
109		54		209	164	320	74
110	101	98		210	261	321	91
111	142	84		211	255	322	74
112		99		212	312	323	63
113	140	14		213	158		912
114		99		214	316		
115	142	84		215	255	North Riser	
116	101	98		216	263	SECTION	# OF SEATS
117		53		217	164	126	168
118		58	6	218	231	127	336
119	180	95	15	219	273	128	168
120	180	95	15	220	178		672
121	180	95	15	221	273		
122	180	95	15	222	178		
123	148	95	15	223	276		
124		110	15	224	180		
125	-	25	2	225	102		
	2363	2014	196		5539		

LOWER LEVEL CAP 4573
200 LEVEL CAP 5539
300 LEVEL CAP 912
NORTH RISER CAP 672
SUITE CAP 30
TOTAL 11726



Seating Section Capacities - Standard Concert Set

SECTION	Lower Level			2nd Level		3rd Level	
	RETRACTABLE	PERMANENT	ADA	SECTION	# OF SEATS	SECTION	# OF SEATS
101		25	2	201	112	303	63
102		105	15	202	180	304	74
103	149	95	15	203	274	305	91
104	180	95	15	204	177	306	74
105	180	95	15	205	275	307	91
106	180	95	15	206	177	308	63
107	180	95	15	207	274	318	63
108		58	6	208	231	319	91
109		54		209	164	320	74
110	115	98		210	261	321	91
111	162	84		211	255	322	74
112		99		212	312	323	63
113	160	14		213	158		912
114		99		214	316	Southend Riser	
115	162	84		215	255	SECTION	# OF SEATS
116	115	98		216	263	7	171
117		53		217	164	8	256
118		58	6	218	231	9	171
119	180	95	15	219	273		598
120	180	95	15	220	178	Floor	
121	180	95	15	221	273	FL 1 (25 Rows)	350
122	180	95	15	222	178	FL 2 (25 Rows)	400
123	148	95	15	223	276	FL 3 (25 Rows)	350
124		110	15	224	180	FL 4 (25 Rows)	350
125	-	25	2	225	102	FL 5 (8 Rows)	128
	-					FL 6 (25 Rows)	350
	2451	2014	196		5539		1928

LOWER LEVEL CAP	4661
200 LEVEL CAP	5539
300 LEVEL CAP	912
FLOOR CAP	1928
SOUTHEND RISER CAP	598
SUITE CAP	30
TOTAL	13368



Seating Charts

End Stage

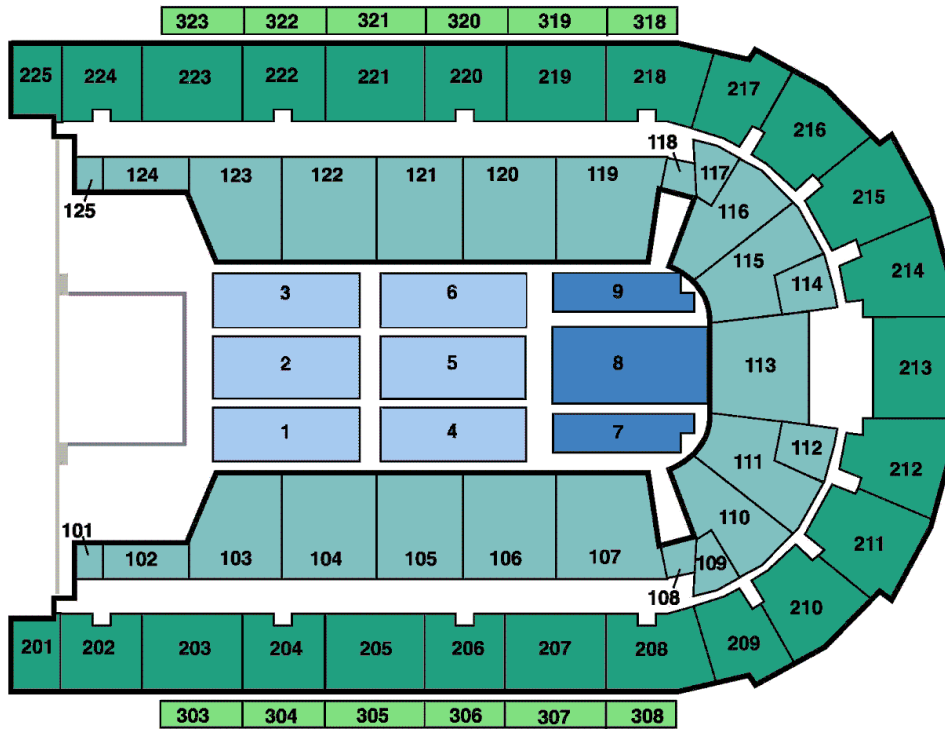

Half House

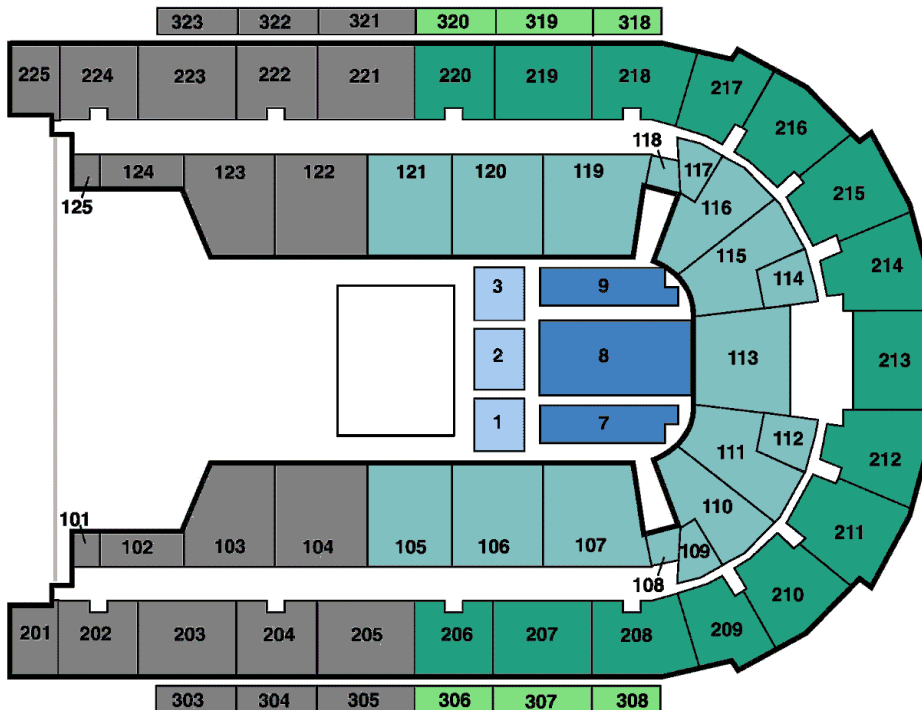

SPECTRA
BY COMCAST SPECTACOR

Boardwalk Hall 45
YOUR BEST SEAT AT THE SHORE

Basketball

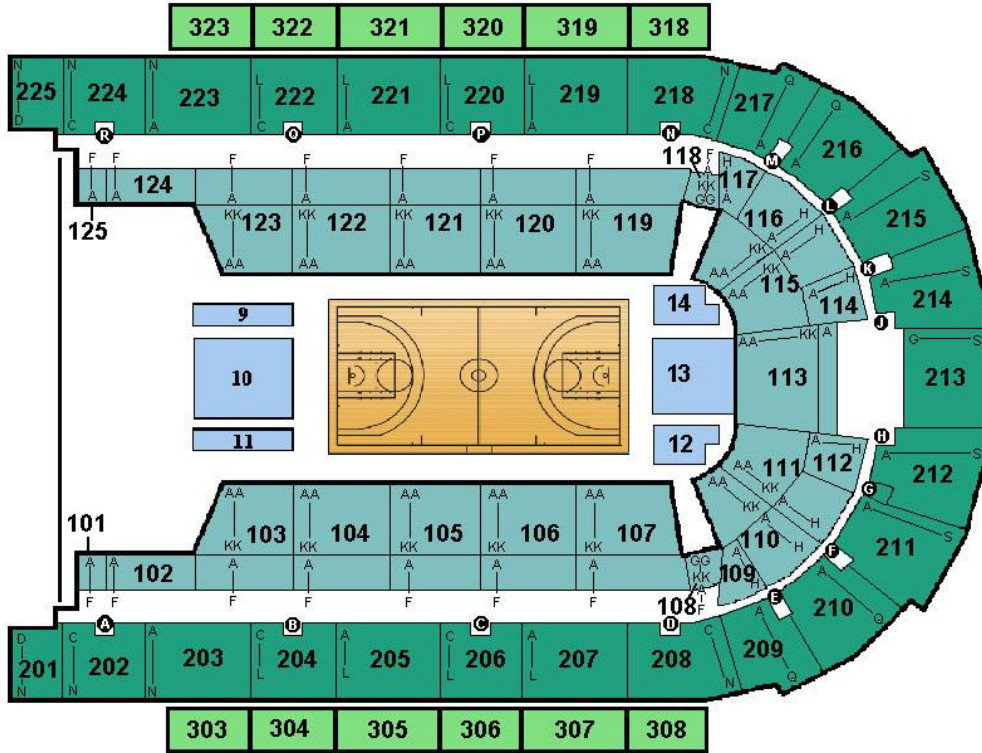

Hockey

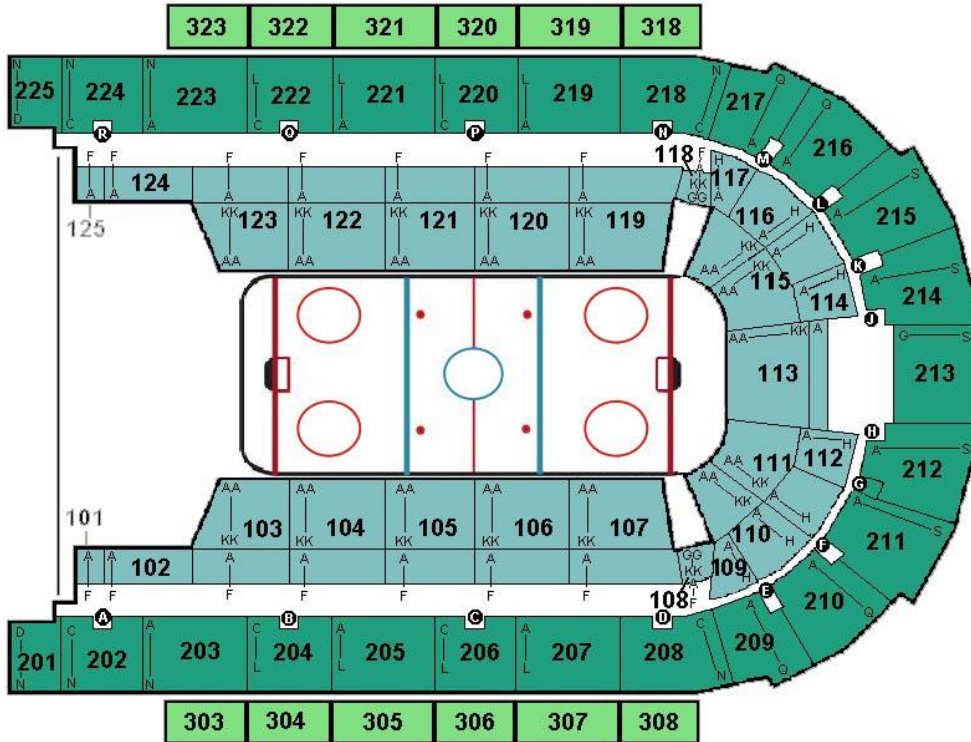

SPECTRA
BY COMCAST SPECTACOR

Boardwalk Hall 46

YOUR BEST SEAT AT THE SHORE

Boxing

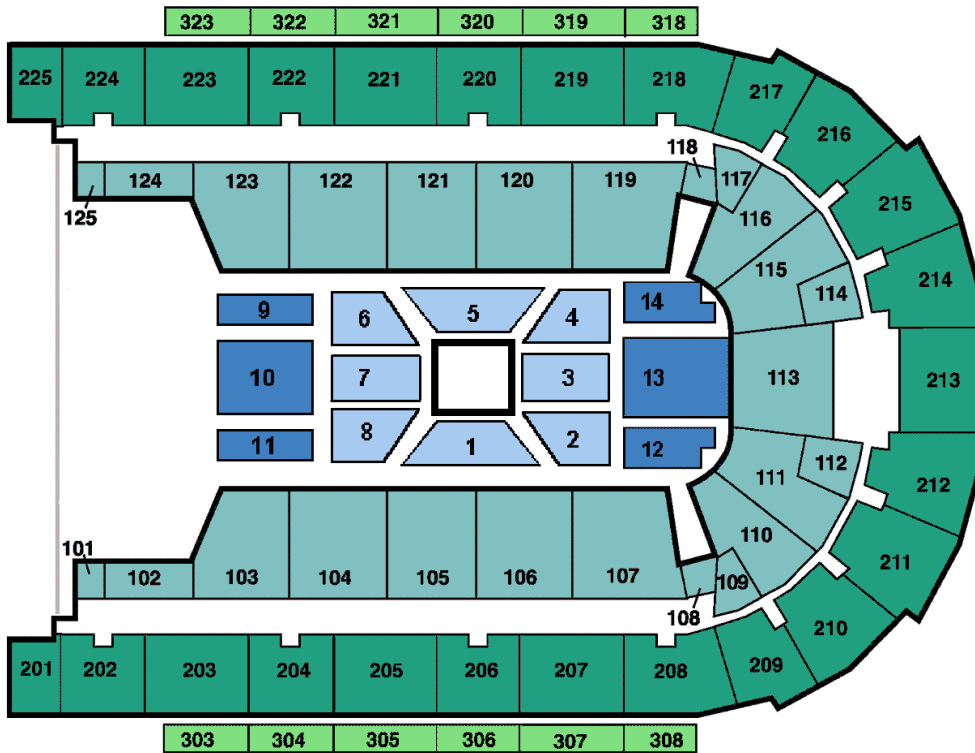

Ballroom – Concert

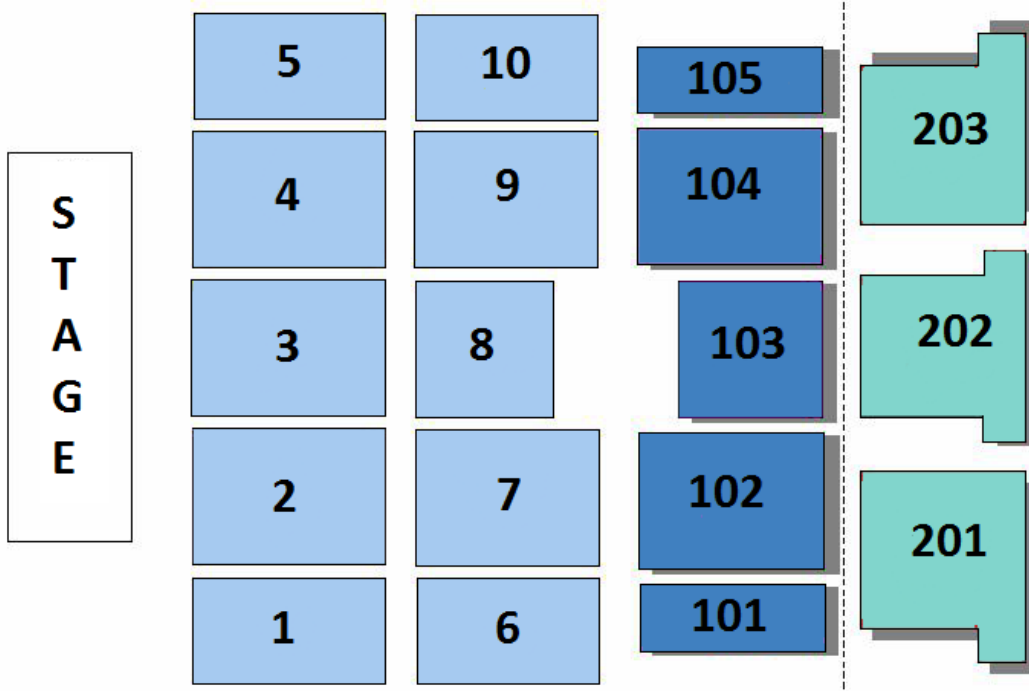

Ballroom – Boxing

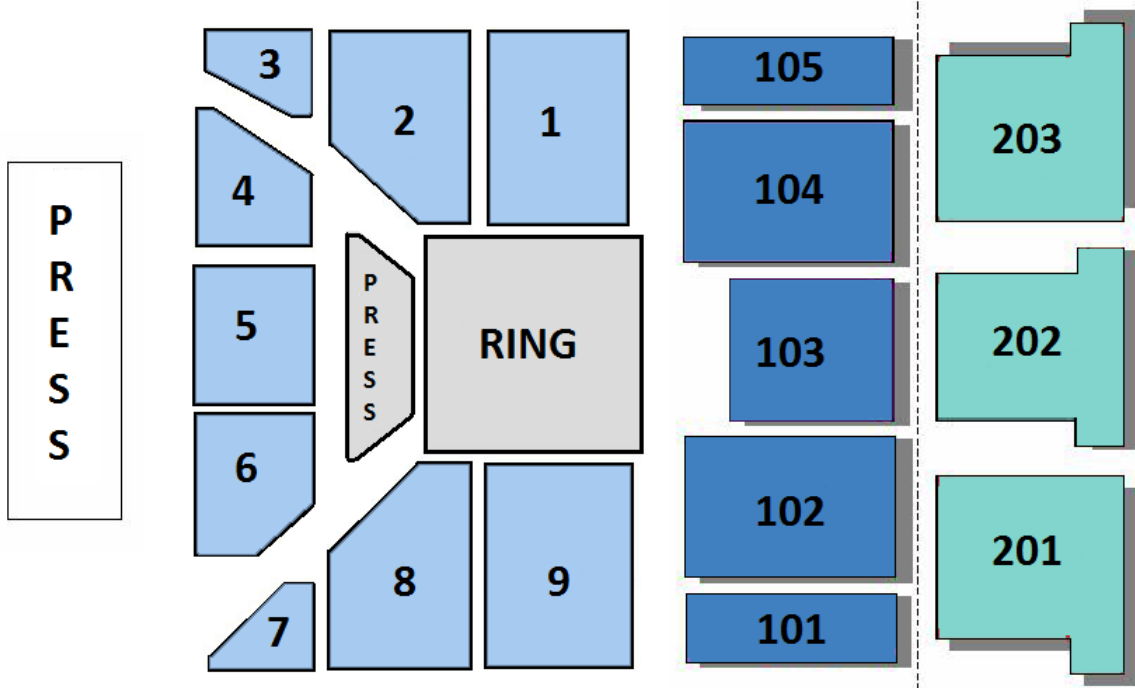

Concourse Map

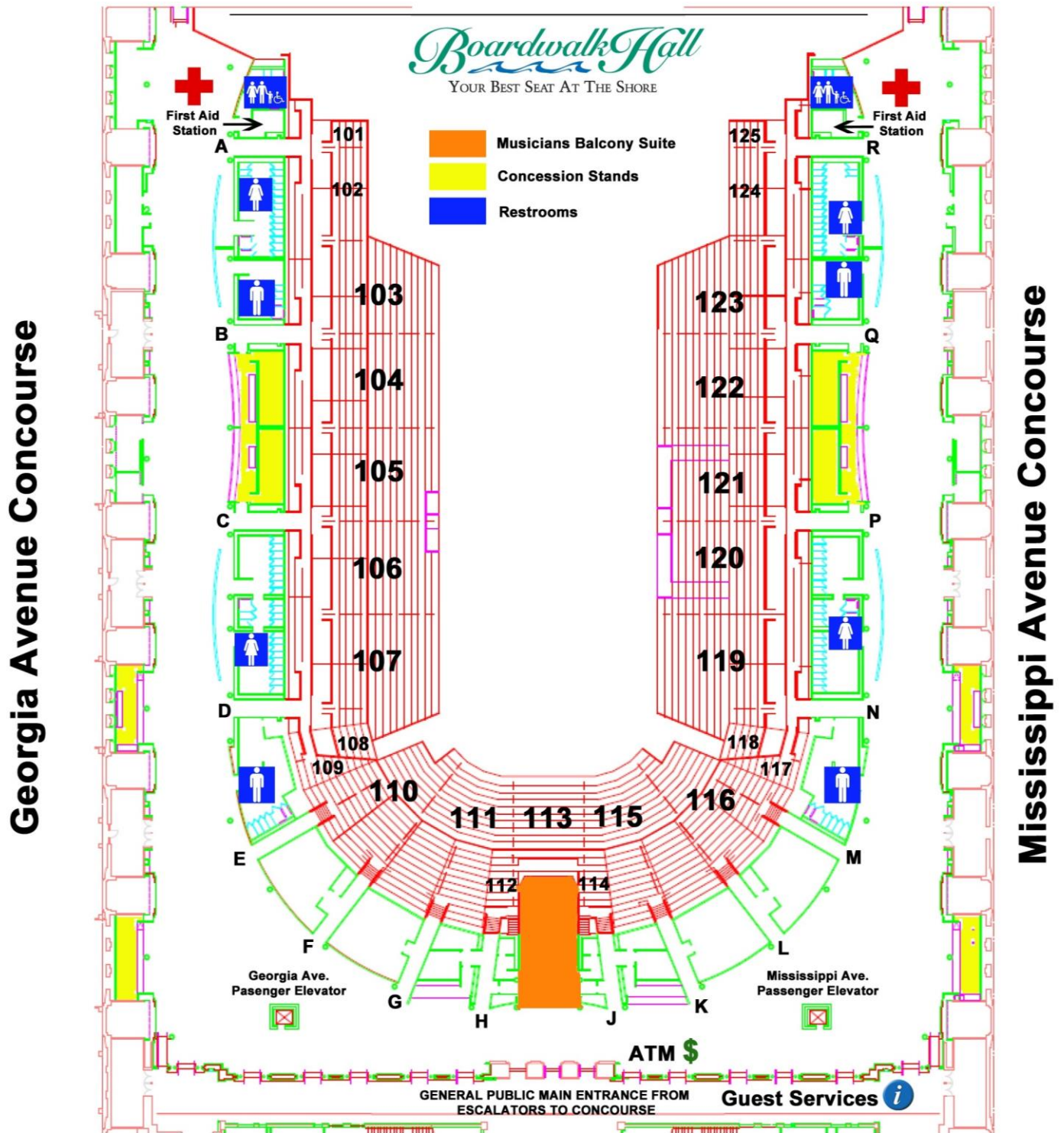

Dressing Room Layout (Stage Left Corridor)

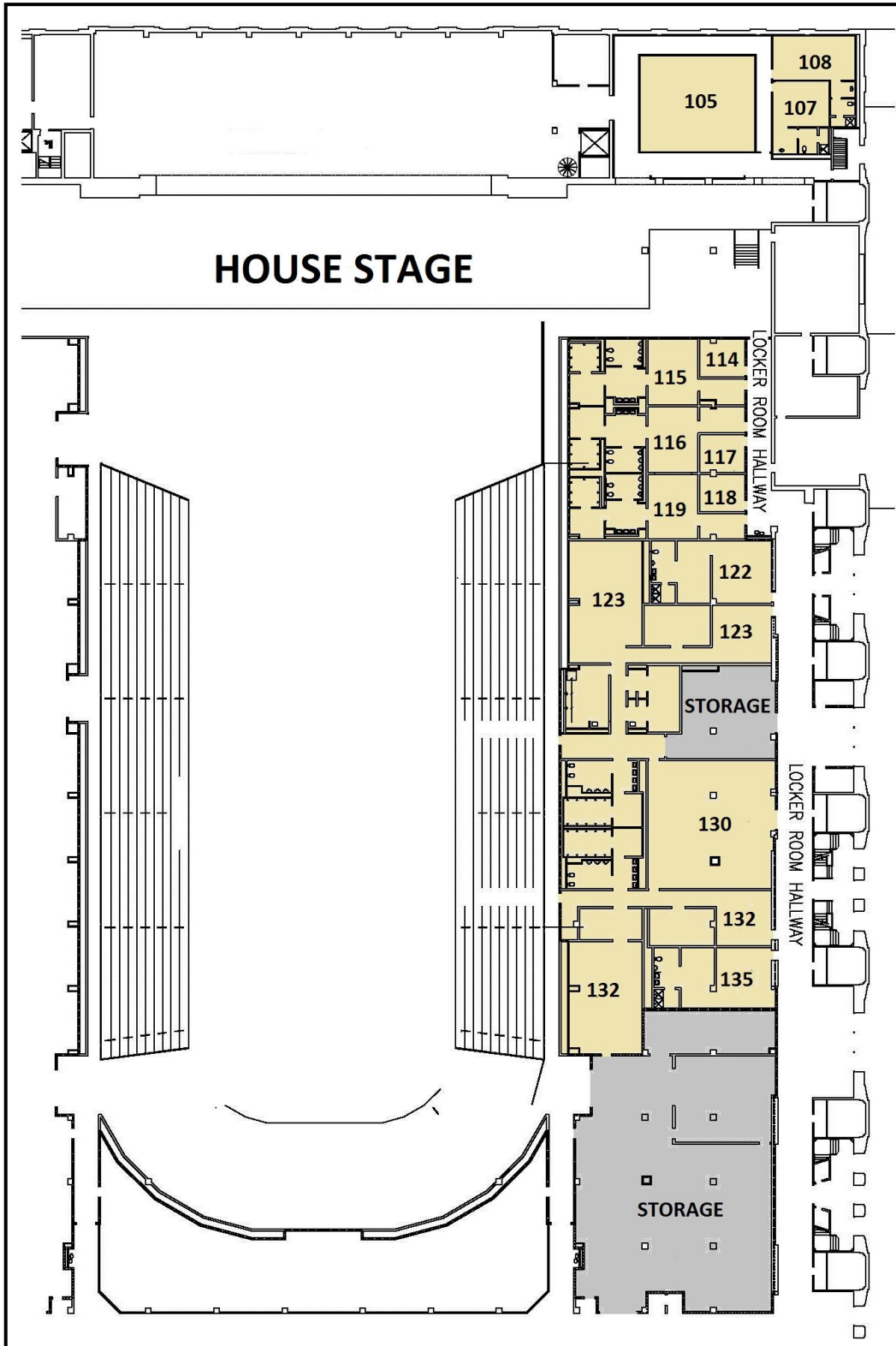

Rigging Grid

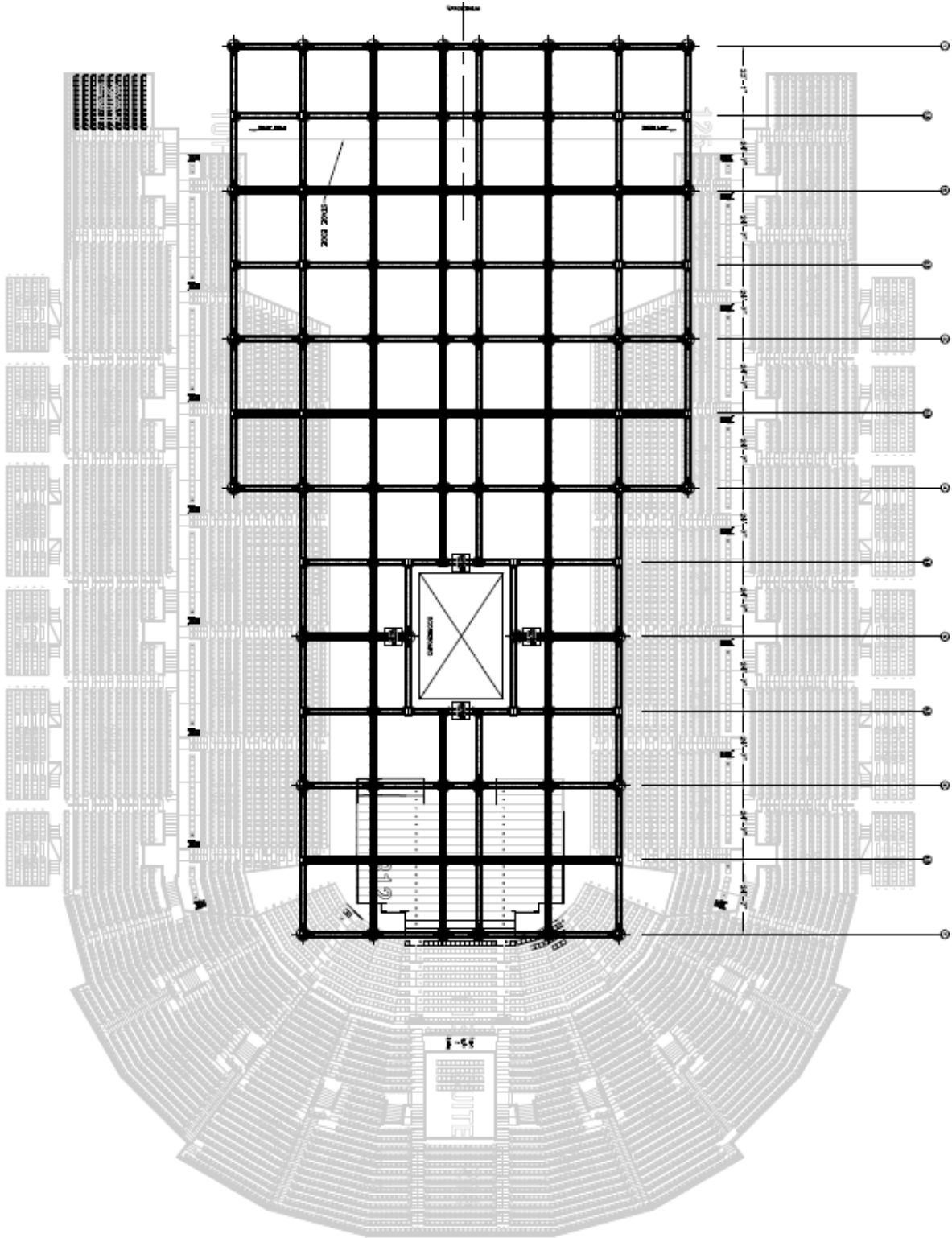

WEST HALL ARRIVAL INSTRUCTIONS

2301 BOARDWALK ATLANTIC CITY, NJ, 08401 – CORNER OF PACIFIC & GEORGIA AVE.

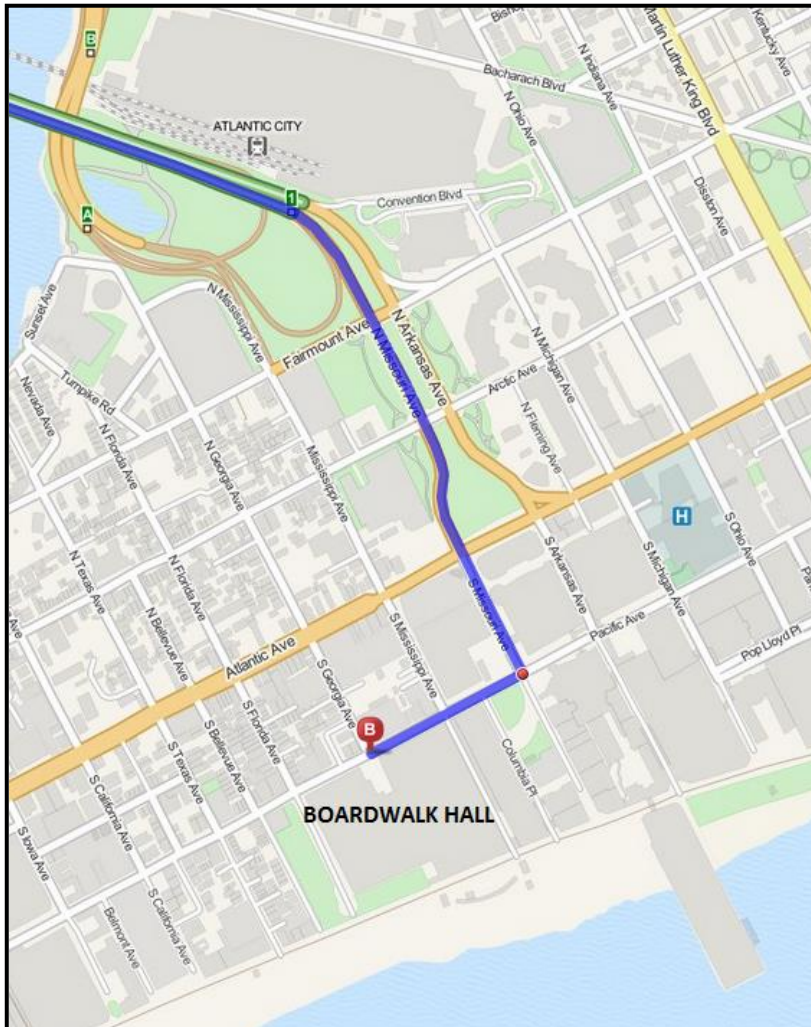

- FROM THE NORTH INTERSTATE HIGHWAYS CONNECT WITH THE GARDEN STATE PARKWAY SOUTH. TAKE EXIT 38 TO THE ATLANTIC CITY EXPRESSWAY.
- FROM THE SOUTH, 1-95 TO DELAWARE MEMORIAL BRIDGE TO ROUTE 40 EAST TO ROUTE 322 EAST, TO ATLANTIC CITY EXPRESSWAY.
- THE ATLANTIC CITY EXPRESSWAY TAKES YOU STRAIGHT INTO ATLANTIC CITY – MIDTOWN.
- WHEN ARRIVING, FOLLOW SIGNS FOR PACIFIC AVENUE ON THE FOOT OF THE EXPRESSWAY.
- TURN RIGHT ONTO PACIFIC AVENUE. BOARDWALK HALL IS LOCATED ON THE LEFT (JUST PASSED TRUMP PLAZA CASINO)
- TAKE A LEFT ON GEORGIA AVENUE AND TURN IMMEDIATELY RIGHT UP THE RAMP INTO UPPER WEST HALL.

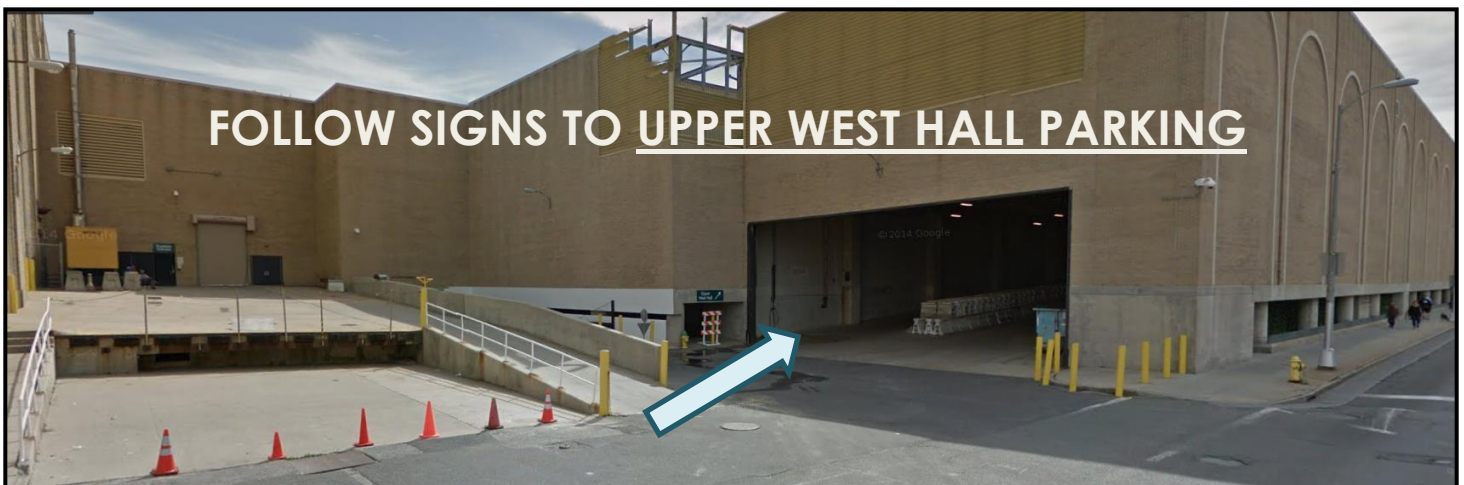

SAMPLE PARKING MAP (WEST HALL)

